

PETROLEUM AND NATURAL GAS REGULATORY BOARD

NOTIFICATION

New Delhi, 16th November 2018

F. No. INFRA/T4S/SC-6/4/18 - In exercise of the powers conferred by section 61 of the Petroleum and Natural Gas Regulatory Board Act, 2006 (19 of 2006), the Petroleum and Natural Gas Regulatory Board hereby makes the following Regulations, namely: -

1. Short title and commencement:

- (1) These Regulations may be called the Petroleum and Natural Gas Regulatory Board (Technical Standards and Specifications including Safety Standards for ¹[dispensing of Automotive Fuels]) Regulations, 2018.
- (2) They shall come into force on the date of their publication in the Official Gazette.

2. Definitions:

- (1) In these regulations, unless the context otherwise requires,
 - (a) “Act” means the Petroleum and Natural Gas Regulatory Board Act, 2006 (19 of 2006);
 - (b) “Annexure” means the Annexure appended to the schedule to which it relates;
 - (c) “Authorised Person “means a person trained and assigned to carry out a specific job by the owner or marketing company;
 - (d) “Approved Type” means any equipment which has specific approval for use under specified conditions by competent authority or authorized person, as the case may be, for such purpose under the law in force;
 - (e) “Board” means the Petroleum and Natural Gas Regulatory Board established under sub-section (1) of section 3 of the Act;
 - (f) “Capacity” means the maximum volume of water that can be stored in a vessel or container at 15°C at atmospheric pressure;
 - (g) “Competent Person” mean a person recognised by the concerned Statutory Authority for the purpose in respect of which the competency is required;
 - (h) “Flame-proof“ means a type of protection in which an enclosure can withstand the pressure developed during an internal explosion of an explosive mixture and that

¹ Subs. by Cl. (1) of Reg. 2, the Petroleum and Natural Gas Regulatory Board (Technical Standards and Specifications including Safety Standards for Retail Outlets dispensing Petroleum, Auto LPG and CNG) Amendment Regulations, 2020, for the words ‘Retail Outlets dispensing Petroleum, Auto LPG and CNG’ (w.e.f. 15.09.2020).

prevents the transmission of the explosion to the explosive atmosphere surrounding the enclosure and that operates at such an external temperature that a surrounding explosive gas or vapor will not be ignited there and such type of protection is referred to in these regulations as "Ex d";

- (i) "Hazardous Area" means the locations classified according to its Zone System which defines the probability of the hazardous material, gas or dust, being present in sufficient quantities to produce explosive or ignitable mixtures and such classification of zones are specified below, namely: -
 - (i) "Zone 0" means ignitable concentrations of flammable gases or vapours which are present continuously or for long periods of time;
 - (ii) "Zone 1" means ignitable concentrations of flammable gases or vapours which are likely to occur under normal operating conditions;
 - (iii) "Zone 2" means ignitable concentrations of flammable gases or vapours which are not likely to occur under normal operating conditions and do so occur only for a short period of time;
 - (j) "Intrinsically Safe" means a type of protection in which the electrical equipment under normal or abnormal conditions is incapable of releasing sufficient electrical or thermal energy to cause ignition of a specific hazardous atmospheric mixture in its most easily ignitable concentrations and such type of protection is referred to in these regulations as "Ex i";
 - (k) "Increased Safety" means a type of protection in which various measures are applied to reduce the probability of excessive temperatures and the occurrence of arcs or sparks in the interior and on the external parts of electrical apparatus that do not produce them in normal service. which may be used with flame-proof type of protection and such type of protection is referred in these regulations to as "Ex e";
 - (l) "Schedule" means the schedule appended to these regulations;
 - (m) "Shall" indicates that the provision in which it occurs is mandatory;
 - (n) "Should" Indicates that the provision in which it occurs is recommendatory but not mandatory;
 - (o) "Type n" means a type of protection applied to electrical equipment that in normal operation, such electrical equipment is not capable of igniting a surrounding explosive atmosphere and such type of protection is referred to in these regulations as "Ex n".
- (2) Words and expressions used in these regulations but not defined therein, and defined in the Act or in the rules or other regulations made there under, shall have the meanings respectively assigned to them in the Act or such rules or regulations,

as the case may be.

3. **Application:**

Definitions, layout, design, operating procedures, maintenance, inspection, safety equipment, competence assurance, emergency management plan, customer safety and awareness shall be construed in accordance with the requirements of these regulations.

4. **Scope:**

- (1) The provisions of these regulations shall apply to all existing and new Retail Outlets dispensing ²[Automotive fuels] such as MS, HSD, Auto LPG, CNG, ³[LNG, LCNG] and their variants.
- (2) The provisions of these regulations shall be construed so as to extend to cover the minimum requirements for engineering and safety considerations in layout, design, operating procedures, maintenance, inspection, safety equipment, electrical power distribution system, automation, competence assurance, emergency management plan, customer safety and awareness at retail outlets dispensing ⁴[Automotive fuels] such as MS, HSD, Auto LPG, CNG, ⁵[LNG, LCNG] and their variants.

5. **Objective:**

These regulations are intended to ensure uniform application of design principles in layout, material and equipment selection, construction and other like requirement in consonance with regulation 3 for safe operation at the Retail Outlets dispensing ⁶[Automotive fuels] such as MS, HSD, Auto LPG, CNG, ⁷[LNG, LCNG] and their variants.

6. **The standard:**

- (1) The technical standards and specifications including safety standards for petroleum retail outlets are as specified in Schedule-I which relate to layout, design, operating procedures, maintenance, inspection, safety equipment, electrical power distribution system, automation, competence assurance, emergency management plan, customer safety and awareness.
- (2) The technical standards and specifications including safety standards for retail outlets dispensing auto LPG are specified in Schedule-2 which relate to layout, design, operating procedures, maintenance, inspection, safety equipment, electrical

² Subs. by sub-cl. (a) of Cl. (2) of Reg. 2, the Petroleum and Natural Gas Regulatory Board (Technical Standards and Specifications including Safety Standards for Retail Outlets dispensing Petroleum, Auto LPG and CNG) Amendment Regulations, 2020, for the words 'Petroleum products' (w.e.f. 15.09.2020).

³ Ins. by Supra 2

⁴ Subs. by sub-cl. (b) of Cl. (2) of Reg. 2, *ibid.*, for the words 'Petroleum products' (w.e.f. 15.09.2020).

⁵ Ins. by Supra 4

⁶ Subs. by Cl. (3) of Reg. 2, *ibid.*, for the words 'Petroleum products' (w.e.f. 15.09.2020).

⁷ Ins. by Supra 6

power distribution system, automation, competence assurance, emergency management plan, customer safety and awareness.

- (3) The technical standards and specifications including safety standards for retail outlets dispensing CNG are specified in Schedule -3 which relate to layout, design, operating procedures, maintenance, inspection, safety equipment, electrical power distribution system, automation, competence assurance, emergency management plan, customer safety and awareness.

⁸[(4) The technical standards and specifications including safety standards for retail outlets dispensing LNG or LCNG are specified in Schedule -4 which relate to storage installations and handling, LNG storage vessel - general design requirements, fitments, equipment, piping system, transfer of LNG, pump and compressor control, tank vehicle unloading facilities, Emergency Shut Down System (ESD System), fire prevention and protection facilities, boil off gas management, LNG or LCNG dispensing, operation and maintenance, road transportation, competence assessment and assurance, emergency plan and procedure, automation, safety inspections or audit.]

7. Compliance to these regulations:

- (1) The Board shall monitor the compliance to these regulations either directly or through an accredited third party as per separate regulations made under the Act on third party conformity assessment.

⁹[(1A) The Board of the concerned entity, within ninety days of the commencement of these regulations shall appoint one of its directors, who shall be responsible for ensuring compliance to these regulations.]

- (2) Any entity intending to set up a retail outlet dispensing ¹⁰[Automotive fuels] such as MS, HSD, Auto LPG, CNG, ¹¹[LNG, LCNG] and their variants shall make available its plan including design consideration conforming to these Regulations to Petroleum and Explosives Safety Organisation (PESO) for their approval.

- (3) If an entity has laid, built, constructed a retail outlet, or which maybe under construction or have expanded the ¹²[Automotive fuels] such as MS, HSD, Auto LPG, CNG, ¹³[LNG, LCNG] and their variants based on some other standard, that is not meeting the requirements specified in these regulations, then, the entity shall carry out a detailed quantitative risk analysis (QRA) of its infrastructure and shall thereafter take approval from its highest decision making body or its board for non-

⁸ Ins. by Cl. (4) of Reg. 2, the Petroleum and Natural Gas Regulatory Board (Technical Standards and Specifications including Safety Standards for Retail Outlets dispensing Petroleum, Auto LPG and CNG) Amendment Regulations, 2020, (w.e.f. 15.09.2020).

⁹ Ins. by sub-cl. (a) of Cl. (5) of Reg. 2, *ibid.* (w.e.f. 15.09.2020).

¹⁰ Subs. by sub-cl. (b) of Cl. (5) of Reg. 2, *ibid.*, for the words 'Petroleum products' (w.e.f. 15.09.2020).

¹¹ Ins. by Supra 10

¹² Subs. by sub-cl. (c) of Cl. (5) of Reg. 2, *ibid.*, for the words 'Petroleum products' (w.e.f. 15.09.2020).

¹³ Ins. by Supra 12

conformities and mitigation measures and such approval along with the compliance report, mitigation measures and implementation schedule shall be submitted to Petroleum and Natural Gas Regulatory Board within six months from the date of commencement of these regulations.

8. Default and Consequences:

- (1) There shall be a system for ensuring compliance to the provisions of these regulations through conduct of technical and safety audits during the construction, commissioning and operation phase,
- (2) In case of any deviation, shortfall or default in compliance to these regulations, the entity shall be given time for rectification of such deviation, shortfall or default and in case of non-compliance, the entity shall be liable for any penal action under the provisions of the Act or termination of operation or termination of authorization to conduct business, or both.

9. Requirements under other statutes:

It shall be necessary for concerned entity to comply with other statutes and the rules and regulations made there under as applicable and to obtain the requisite approvals from the concerned competent authorities for retail outlet dispensing ¹⁴[Automotive fuels] such as MS, HSD, Auto LPG, CNG, ¹⁵[LNG, LCNG] and their variants.

10. Miscellaneous:

- (1) If any dispute arises with regard to the interpretation of any of the provisions of these regulations, the decision of the Board thereon shall be final.
- (2) The Board may at any time, by order and in appropriate cases make such relaxation in any provision of these regulations as may be specified in the order.
- (3) The Board may issue such guidelines consistent with the Act and the rules and regulations made thereunder for the proper implementation of these regulations as it may deem fit.

¹⁴ Subs. by Cl. (6) of Reg. 2, *ibid.*, for the words 'Petroleum products' (w.e.f. 15.09.2020).

¹⁵ Ins. by Supra 14

SCHEDULE 1

[See regulation 6(I)]

STORAGE, HANDLING AND DISPENSING AT PETROLEUM RETAIL OUTLETS

1.0 SCOPE:

The technical standard and specifications including safety standards under this Schedule lays down the minimum requirements in design, operation, inspection, maintenance, training, consumer safety at petroleum retail outlets (PRO) and do not cover the certification or fitness requirements of vehicles.

2.0 DEFINITIONS:

In these regulations, unless the context otherwise requires-

- (a) C-Store means convenience stores, the area in which non-fuel goods or consumables are sold;
- (b) Dispenser means equipment provided for delivering MS or HSD to the auto fuel tank of motor vehicles or approved receptacles;
- (c) Emergency shut off means a shut off to cut off power supply as well as product supply which in an emergency, operates automatically or can be operated remotely;
- (d) Fill Point means the point of inlet pipe connection of a bulk storage tank for MS or HSD where hose is connected for filling the products into the tank;
- (e) Petroleum Retail Outlet (PRO) means area approved by PESO and provided with facilities, specially designed for storage and dispensing to the fuel tanks of motor vehicles and any other approved receptacles; and
- (f) Pressure Vacuum Valve means a pressure and vacuum relief device fitted on top of the vent pipe of the tank to limit the maximum pressure and vacuum that can exist in storage tank and vessel;
- (g) Product Classification means Class A – Flash Point below 23 deg C. Class B – Flash Point between 23 deg C and 65 deg C. Flash point of a volatile liquid is the lowest temperature at which it can vaporise to form an ignitable mixture in air;
- (h) Sales Room means an office space to conduct the business of the retail outlet, housing amenities like toilets, change rooms, storage space, automation equipments and like other activities;
- (i) Tank Truck or Tank Lorry or POL Tank Lorry means a truck mounted with a properly designed and PESO approved tank for transportation of MS or HSD in bulk to the dispensing stations.

(j) Vent Pipe means the pipe fitted on an underground tank for breathing;

3.0 LAYOUT AND FACILITIES:

3.1 General:

- (i) The layout should ensure unobstructed movement of vehicles and provision for entry and exit of Tank trucks;
- (ii) Location of the facilities, equipment, entrance, exit and paving shall be arranged in such a manner so as to avoid the risk of any collision amongst the motor vehicles;
- (iii) All Facilities should have access to mobile fire fighting equipments;
- (iv) The location of tanks, fill and vent pipes, dispensing equipment and tank truck decanting area, onsite buildings, shall be so designed to enable means of escape for persons, in the event of fire or any other incident;
- (v) The fuel lines and electrical cables will have positive segregation;
- (vi) No source of ignition shall be allowed in the hazardous areas;
- (vii) The items to be stored, and sold from a Convenience Store (C-Store), shall keep in view associated fire hazards and open or naked flame appliances are not permitted;
- (viii) C-Store parking should be away from entry or exit and not impede the free flow of traffic; and
- (ix) Hazardous area classification shall be done in line with IS: 5572.

3.2 Storage Tanks:

- (i) Class A and B Petroleum products shall be stored only in underground tanks in single or double membrane (walled) and its installation shall be outside the buildings;
- (ii) Tanks shall be placed in an earthen or masonry or concrete pit, and shall be packed with sand or earth or gravel, without leaving any space around the tank and when tank is installed in earth pit, no part of the tank shall be less than 1.5 metre from any point of the marked boundary; and.
- (iii) No part of the space over the buried tanks, shall be used for any purpose, other than installing equipment, specifically meant for the withdrawal or receipt or monitoring of contents of the tank, or for the purpose mentioned under paragraph 3.3.2.1 of this Schedule.

3.2.1 Material of construction:

Following materials shall be used for construction of underground storage tanks; namely: -

Steel tanks: Carbon steel as per IS: 2062 or equivalent;

Design Code IS: 10987: 1992 for petroleum products or equivalent; and Fiberglass reinforced plastic tanks (FRP Tank): ASTM D4021, conforming to UL 1316 or equivalent.

3.3 Tank Installation:

- (i) The underground tanks shall be either installed in the dedicated tank farm area “Away from Driveway (Remote Tank Farm)” or under the driveway with an appropriate reinforced concrete slab or alternate pavement material;
- (ii) All tanks shall be pressure tested using pneumatic or hydro, as per the design code or operating pressure, whichever is higher, before commissioning;
- (iii) Steel tanks shall be protected against corrosion;
- (iv) Design and Installation shall provide protection against buoyancy; and
- (v) Installation of tanks shall follow the manufacturer’s recommendations;

3.3.1 Tanks installed under driveway:

- (i) Underground tanks shall be installed under concrete slab or alternate pavement material and design consideration shall take care of loading either through masonry pit walls or back fill material and burying depth of tanks;
- (ii) Manway covers (metallic or alternate material) shall be designed for the intended vehicle load and ensure safety of tank fittings;
- (iii) RCC slab or alternate pavement for the tank pit to be designed for the intended vehicle load.

3.4 Fill points:

- (i) The fill points for the tank or tanks, whether offset or direct fill, shall be located in such a manner, so that any spillage of petroleum and its subsequent ignition, does not pose any immediate threat, to the public or retail outlet staff;
- (ii) Fill points shall be located in the open air, so that any flammable concentrations of vapours, resulting from normal filling operations or spillage, does not reach potential ignition sources, or tends to accumulate;
- (iii) The fill points shall maintain a minimum safety distance of 3 mtrs. all round, including property boundary or any other structure, where a source of ignition is likely to be present and this distance of 3 m may be reduced, if a fire – resistant wall is constructed, e.g. of brick or concrete, which is at least 2 m high and of 4 hours fire resistant rating (conforming to IS 1642) and if the wall is a part of a building which houses a sensitive population, such

as a school, hospital or residential dwelling, then this distance should be increased to 12 m;

- (iv) Fill pipes shall have minimum 1:200 slopes towards the storage tank, to ensure easy flow due to gravity, and also to avoid any product retention within the fill pipe;
- (v) Fill pipe shall be carried down nearly to the bottom of the tank, to prevent fire hazard due to generation of static charge, arising out of free fall of product;
- (vi) Identification for various types of fuels, shall be provided to avoid wrong decantation;
- (vii) An “earthing bus” shall be provided in the close vicinity of fill points;
- (viii) Hose connections shall be properly tightened;
- (ix) Fill pipe caps shall be made of softer material like brass or aluminum;
- (x) Fill cap shall have a proper locking system, and key shall be kept under the custody of the authorized person; and
- (xi) Fill points shall be so located, that the tank lorry under decantation, is in drive out position;

3.4 Pipelines:

- (i) Pipelines from tanks to dispensing points, and vent pipes shall be routed below the ground and it shall not be under a building, or other features, which prevent access to the pipelines and Fuel Pipes should be sloped towards underground storage tank;
- (ii) In case of pressurised system, entire piping system including the appurtenances, shall preferably be constructed with welded joints and the number of flanged joints shall be kept to a minimum;
- (iii) Piping shall run with as few restrictions, such as elbows and bends, as conditions permit;
- (iv) Each pipe line shall be hydro tested as per design code and alternatively, it shall be hydro tested at 1.5 times the design pressure maintained for a period of at least 30 minutes;
- (v) Where necessary, pipe lines shall be earthed, and to maintain electrical continuity, suitable “Jumpers” are to be provided at the flanged joints; and
- (vi) In case of metallic pipelines, the same shall be protected against corrosion, by suitable wrapping and coating, and where necessary by cathodic protection.

3.5.1 Material of Construction:

- (i) Specifications of material for metallic piping and fittings shall conform to IS-1978 or equivalent; and

- (ii) Material specifications for non-metallic piping and fittings shall conform to UL 971, EN 14125 or equivalent.

3.6 Vent pipes:

- (i) Each tank shall be provided with independent vent pipe or pipes of adequate capacity, unless vapour recovery system is installed;
- (ii) Vent point shall not be located under any shade or cover;
- (iii) Open ended vent pipes, shall extend to a height greater than the maximum liquid level of a road tanker that delivers petroleum to the underground tanks, and shall not be less than 4 mtrs and in case of venting above the canopy or sales building, the vent pipes shall be terminated 1.5 mtrs. above it;
- (iv) The vent pipe opening, shall also observe minimum 4 mtr and clearance shall be in the horizontal plane, from all structures;
- (v) The vent pipe shall be protected against damage, by inadvertent collision with vehicles;
- (vi) The outlet (opening) of the vent pipe shall be covered with two layers of non-corrosive metal wire mesh, having not less than 11 meshes per square centimeter, and a rain cap or bend downwards;
- (vii) Vent pipe shall be gradually sloped towards the tank, to avoid chocking of vent pipe due to any water ingress, or due to product, in the event of tank overflow; and
- (viii) The vertical portion of the vent pipe shall not be provided with any intermediate thread joint.

3.7 Dispensing Equipment:

- (i) Dispensers shall be located so that these are adequately ventilated;
- (ii) The dispensers shall maintain a minimum distance of 6 mtrs, from any above-ground structure or property boundary and for Pump islands catering exclusively to 2/3 wheelers, this distance from boundary wall or other permanent structures, may be reduced to 4M, while limiting the length of the hose pipe to 3 M;
- (iii) The dispenser shall be installed on a firm foundation and protected against physical damage from vehicles;
- (iv) A shear valve to be provided in dispensers in a pressurised system;
- (v) The length of the hose connected to the dispenser, shall be kept minimum, keeping in view the operational requirement, and not exceed 4 m;
- (vi) Breakaway coupling shall be installed in dispensing hose or nozzle;

- (vii) The dispensing hose shall be electrically and mechanically continuous and earthed and necessary provisions shall be available in Dispenser, to earth the receptacles other than fuel tank of vehicles; and
- (viii) Installation of any electronic peripheral device, shall be done at a 1200mm, above the base level of the dispensing unit.

3.8 Decantation Area:

- (i) The tank truck delivery locations for unloading into storage tanks, shall be level, in the open, away from the sales building, dispensing activities and emergency escape routes;
- (ii) The hose used shall conform to IS 10733;
- (iii) Hose length shall not be more than 5.5 m; and
- (iv) The location chosen, shall allow the TT to gain access, without the need to reverse on to the site, but, reversing under supervision for positioning the road tanker for placement in drive-out position shall be permitted.

3.9 Sales Room:

- (i) Any building or room, intended to serve as a control point, shall preferably be so located, that an attendant in the sales room, can see the forecourt and the dispensing area clearly.

3.9 Canopy:

- (i) The canopy shall not adversely affect the ventilation or access to the equipment;
- (ii) Canopy heights installed at fuel fore court, shall have at least 300mm clearance from the maximum permitted height, recommended by Central Motor Vehicle Rules, 1989 for the vehicles to be fueled;
- (iii) Wind and seismic load for the canopy design, shall be considered as per IS: 875 and IS: 1893 respectively; and
- (iv) Canopy structure shall be properly earthed as per IS: 3043.

4.0 Electrical Power Distribution System:

The following elements and components shall be considered in designing the electrical power distribution system; namely: -

- (i) Total electrical load for the entire Retail Outlet;
- (ii) Availability, Suitability and Reliability of the State Electricity Board (SEB) grid;
- (iii) Fault (KA) rating of the SEB Feeder;

- (iv) Load to be fed from back-up;
- (v) Load which need stabilized or Uninterrupted Power Supply (UPS) supply, or both to function smoothly; and
- (vi) Rated load of the connected and future equipment.

For downstream distribution on the LT side, a suitable LT power distribution panel (PDP) shall be designed, to feed the various types of loads safely, from a centralized location.

4.1 Elements of Protection:

- (a) Protection shall be provided to guard against sudden failures viz. disconnection of “Neutral” and against overload, short-circuit and earth fault;
- (b) The motors shall be protected against short circuit and overload; and
- (c) Protection shall be provided for variation in voltage, frequency and phase imbalance.

4.2 Backup Power Supply:

4.2.1 The following shall be considered to arrive at the capacity of the Diesel Generator (DG) set or Renewable Energy system and like other set or system, if provided; namely: -

- (i) “Critical” lighting fixtures; and
- (ii) The Backup rating shall be sufficient enough, to sustain the starting power requirements, of the connected motors, without disturbing normal operation of the other loads.

4.2.2 When operating before sunrise or after sunset, emergency lighting shall be provided for safe operation of power backup equipment.

4.3 Layout and Installation:

- (i) For HT supply, the substation shall mainly consist of lightning arrestor, HT fuse, transformer and SEB metering cubicle and for retail outlets with an outdoor type of HT or LT substation, a DP structure surrounded with barbed wire fence, entry gate shall be provided and alternatively, a packaged sub-station shall be provided.
- (ii) The power distribution panel, automatic voltage stabiliser and UPS shall be installed with following clear spaces for ease of safe operation and maintenance activities:

- in front of the equipment - 1000 mm.
- behind the equipment - > 750 mm. (if approach is required)
- < 200 mm (if approach is not required)
- at sides - > 750 mm. Between equipments
- < 200 mm. (if approach is not required);

- (iii) Electrical room shall be provided with proper ventilation to extract the heat generated in the power distribution equipments;
- (iv) All electrical equipment shall be as per IS: 5571 in line with hazardous area classification and the zone classification has been depicted in Annexure-I;
- (v) Cable entry shall be through gland plate either at top or bottom and further spare holes, if any, in the gland plates shall be blocked;
- (vi) Cables shall be neatly dressed, clamped and tag marked to easily identify the feeder and device it connects;
- (vii) The cable entry holes on the building wall in cable trench or overhead shall be sealed to prevent entry of water; and
- (viii) For underground laying under different conditions of terrain the methods may be as follows; namely: -
 - (a) For direct burial within PRO, top of the topmost layer of cable shall be laid at a minimum depth of 600 mm from surface of ground and each subsequent layer at the bottom shall maintain a minimum vertical clearance of 150 mm; and
 - (b) For road crossings, cables shall be routed at a minimum depth of 600mm from surface and thru pipe and the pipe may be of GI or steel reinforced hume pipe or HDPE pipe.

4.4 Earthing System:

The earthing system shall be designed as per IS 3043 and following procedures shall be followed; namely: -

- (i) All metallic structure, pipe fittings and enclosures of electrical equipments shall be connected to earth.
- (ii) For Equipment rated up to 230 V, 1-phase supply, the enclosure shall be grounded at least at one point.
- (iii) And for Equipment rated above 400 V, 3-phase supply, the enclosure shall be grounded at least at two separate points.
- (iv) Two nos. earth pits shall be provided for each of transformer or DG set neutral earthing / equipment earthing.
- (v) All earthing pits except DG neutral, structure, T/T Unloading point and instrument or IT earthing shall be connected through grid or grids; and

- (vi) In areas prone to lightning, a risk assessment shall be carried out for need of lightning protection and guidelines given in IS 2309 shall be followed.

4.5 Emergency Stop System:

- (i) Emergency stop system shall be provided to cut off the power supply to all metering pumps or dispensing equipment and associated equipment, other than certified intrinsically safe equipment at PDP, and in or on sales building and on actuating any of these push buttons, electrical power supply to entire PRO, except yard lights, shall be isolated instantaneously; and
- (ii) The push button shall be of red colour, mushroom type, marked and with a key to open.

4.6 Illumination System:

Following minimum illumination level (Lux) shall be maintained in various areas of the PRO for safety and visibility; namely: -

Area	LUX
Approach area	50
Under the canopy	150
Customer care room	100
Electrical room or compressor area	100

The design shall ensure that illumination is glare-free for customers driving in.

5.0 Automation:

5.1 Components of Forecourt Automation:

Retail automation (Forecourt control) where provided, shall have following major components and these components are integrated together using different communication methods; namely: -

- (i) Forecourt controller (FCC);
- (ii) Back office system;
- (iii) Local area network (LAN);
- (iv) Wi-Fi access points;
- (v) VSAT or GPRS or broadband routers cum modem;

- (vi) Automatic tank gauging system (ATG);
- (vii) Electronic price signs (EPS);
- (viii) Payment terminals;

- (ix) Thermal receipt printers;
- (x) Attendant tag readers; and
- (xi) Close Circuit surveillance systems (CCTV);

These components shall be evaluated for necessary approvals based on their location of installation in conjunction with the zone classification guidelines for retail outlets and accordingly each of these components is described briefly in Annexure II.

5.2 Installation of Automation Components:

- (i) The components installed in Zone-0 and Zone-1 shall be certified for use by competent certifying agencies;
- (ii) The integrity of the dispenser shall remain intact, while adding additional cables for communication, as well as power supply to OPT or printer and similar devices;
- (iii) The installation of auto tank gauging equipment probe, shall be carried out in compliance to relevant standards, using safe arrangement for joining of the cable at the tank manhole area;
- (iv) The height of pedestals used for installing, printers, outdoor payment terminals and similar equipments shall not be less than 1.2 mtrs. from the base frame of the dispensing unit; and
- (v) The integration of automation components and its installation shall be done under the supervision of qualified and trained personnel

6.0 OPERATING PROCEDURES:

6.1 General:

- (i) Operating personnel shall possess adequate knowledge and experience of handling MS or HSD to ensure safe and efficient functioning.
- (ii) Dos and don'ts in consonance with paragraph 12.2 of this Schedule shall be prominently displayed;
- (iii) Action in the event of emergency shall be clearly established, understood and displayed prominently; and
- (iv) The following are the critical activities, namely: -
 - (a) Decantation;
 - (b) Management of the forecourt or fueling area; and
 - (c) Sampling.

6.2 Decantation of Tank Lorries:

6.2.1 On receipt of tank lorry from the supply point, dealer or his authorized representatives shall check the supply point documents with respect to seal numbers, number of compartments and quantity of product contained therein and the unloading operations shall be done in presence of the authorised personnel of retail outlet and tank truck crew and the following precaution shall be followed up, namely: -

- (i) During unloading of the product from the tank truck to the bulk storage vessels, the tank truck shall be parked in the identified space;
- (ii) Dispensing fuel to motor vehicles, shall be suspended during the period of unloading of fuel, from tank truck to the storage tanks;
- (iii) Operations shall be suspended during the period of evacuation of product from storage tank for maintenance and testing;
- (iv) MS or HSD shall not be filled in the fuel tank while the engine of the vehicle is running; and
- (v) The operating procedures shall be displayed for the unloading of tank truck.

The safety checklist for tank lorry decantation should be as per Annexure VII.

6.2 Refueling:

- (i) Guide the vehicle to the designated position;
- (ii) Vehicle should not be left unattended during refueling;
- (iii) Sources of ignition, such as pilot lights, electrical devices or appliances or gadgets and engines shall be turned off before dispensing of fuel to the vehicle; and
- (iv) Riders or pillion shall dismount before the commencement of refueling.

6.3 Handling of Fuel Samples:

- (i) The samples shall be taken in approved containers;
- (ii) The samples shall be stored safely in the designated area which is not used for any other activity;
- (iii) For class A product, total storage in sample containers shall not exceed 30 litres; and
- (iv) The samples shall not be poured back directly to the storage tank and the samples shall be collected in a separate receptacle for each product and transferred to storage tank through a container which is bonded to tank.

7.0 INSPECTION AND AUDITS:

- (i) A well-designed system of periodic inspection of all facilities shall be ensured to maintain it in safe operable condition and checklist shall cover conformity with the design intention, operating and maintenance procedures, preventive measure and protection systems and safety practices;
- (ii) Safety audit should be undertaken as per format provided in Annexure -V;
- (iii) Recommendations of the safety audit or inspections shall be complied in a time bound manner and records maintained thereof;
- (iv) The system of “permit to work” shall be established for non-routine works and such works shall be undertaken with full knowledge and approval by authorised person;
- (v) Dispensing unit shall be tested, maintained, repaired and replaced as recommended by the manufacturer and approved by the concerned authority;
- (vi) The Resistance to Earth shall be checked at least once a year; and
- (vii) The periodicity of inspections and audit shall be as given below, namely: -

TYPE	FREQUENCY	AGENCY
Safety Inspection	Weekly	Operating personnel
Safety Audit	Once in a year	Company authorized Person or Agency
Electrical Audit	Once in 3 years	Company authorized Person or Agency

The typical checklist for these inspections or audits are provided in Annexure-III, Annexure-IV and Annexure-V which shall be used as a guideline to develop comprehensive checklists to check compliance and also proper system to liquidate the non-complied points with target dates.

8.0 MAINTENANCE:

8.1 GENERAL:

- (i) A comprehensive maintenance system of all facilities shall be formulated for safe operable condition;
- (ii) Preventive maintenance schedules shall be drawn for all equipment, in accordance with manufacturer’s recommendations, and established mandatory or recommendatory standards. records of all preventive maintenance undertaken shall be maintained;

- (iii) Repairs involving non-routine maintenance work, shall be carried out after issuance of work permit, as per the procedure and format provided in Annexure – VI (a) and VI (b).
- (iv) The work permit shall be issued by company authorized person or dealer or manager, at the retail outlet, as per the class of activities detailed in succeeding clauses (v) and (vi);
- (v) Work Permits issued by dealer or manager or company authorized person

The following activities involving maintenance of operational area and office requires work permits to be issued by dealer or manager or company authorized person to contractor or his authorized person, namely: -

- (a) Access to a building or canopy roof;
 - (b) Access to a building canopy cavity;
 - (c) Electrical switch board work;
 - (d) Excavation including forecourts up to 1meter depth;
 - (e) Forecourt surface repair;
 - (f) Water removal from underground tank through hand pump;
 - (g) Repair of electrical and electronic equipments inside hazardous area (operation of all electrical and electronic instruments inside hazardous areas, unless certified intrinsically safe);
 - (h) Promotional activities on forecourts;
 - (i) Signage, including canopy signage or lighting works; and
 - (j) Replacement or installation of dispensing Units;
- (vi) Work Permits issued by company authorized personnel only:

The following activities involving maintenance of Operational area and office requires work permits to be issued by company authorized person to contractor or his authorized person, namely: -

- (a) Repair or rework or cleaning of the tanks and pipeline work;
- (b) Tank removal and decommissioning;
- (c) Non-routine maintenance or replacement or major electrical work within hazardous area;
- (d) Entry in oxygen deficient or inert gas area;

- (e) Pneumatic or hydrostatic pressure testing;
- (f) Cleaning of oil interceptor, oil or water separator and like other things;
- (g) Hot work including but not limited to welding or grinding or gas cutting;
- (h) Demolition and revamping (remodeling);
- (i) All activities capable of producing a spark inside a hazardous area;
- (j) Excavation including forecourts exceeding 1-meter depth;
- (k) Concrete cutting in the hazardous Zone; and
- (l) Setting up of temporary equipment including product recovery equipment e.g. compressor, water or sand blasting equipment and like other things.

9 SAFETY EQUIPMENT:

- (i) Each dispensing unit shall be provisioned with 1 no. ISI marked 9 kg DCP fire extinguishers placed near the island, but, at outlets with single dispensing unit, a minimum of two no. ISI marked 9 kg DCP fire extinguishers shall be provided;
- (ii) Minimum 1 no. 4.5 kg CO2 fire extinguisher conforming to IS: 2878 shall be available in each electrical meter room;
- (iii) Minimum 4 nos. sand buckets filled with dry sand should be available;
- (iv) All employees must be conversant with the safe handling of petroleum products and have first-hand knowledge of fire fighting and emergency handling;
- (v) Only insulated pliers or screw drivers, non-sparking tools and flameproof torch shall be used;
- (vi) Periodic tests shall be carried out by competent or authorized persons, as applicable and records shall be maintained;
- (vii) Fire extinguishers are to be periodically tested and maintained as per IS standard; and
- (viii) The fire extinguishers are to be checked, tested and maintained as per following schedule and complying with IS standard, namely: -
 - (a) Visual check of the extinguisher : Daily
 - (b) Condition of DCP, Hose, Nozzle and safety clip : Every month
 - (c) Weight checking of CO2 cartridge : Every Quarter
 - (d) Performance testing and DCP extinguisher : Every Year

(e) Pressure testing of extinguisher
years)

: As per IS 15683 (currently 5

10.0 EMERGENCY PLAN AND PROCEDURE:

- (i) A comprehensive ERDMP shall be developed in accordance to the Petroleum and Natural Gas Regulatory Board (Codes of Practices for Emergency Response and Disaster Management Plan (ERDMP)) Regulations, 2010 and the copies of the ERDMP shall be available to all concerned personnel;
- (ii) Provision of minimum 2 points for emergency shutdown shall be maintained;
- (iii) The operating company having control shall draw an operational emergency plan incorporating the following, namely: -
 - (a) Major failure of fittings resulting in spillage;
 - (b) Accidents or other emergencies;
 - (c) Electrical Emergencies;
 - (d) Civil emergencies; and
 - (e) Any other risk arising from the existence or operation.

The above emergency plan shall be disseminated amongst all personnel involved to ensure that they understand their roles and responsibilities;

- (iv) The retail outlet in-charge shall maintain close liaison with Fire Service, Police and District Authorities;
- (v) Important telephone numbers for emergency use shall be displayed prominently;
- (vi) Means of communication shall be always at the disposal of the In charge of the retail outlet;
- (vii) Emergency action plan should be tested with mock drill at least once a year.
- (viii) First aid kit shall contain items to handle possible emergencies as per Rules applicable to factories in the concerned State for such purpose; and
- (ix) Electrical shock treatment chart written in bilingual (English and local languages) and RO attendants shall be given training on how to treat an electrocuted person before help from a doctor is available.

11.0 COMPETENCE, ASSURANCE AND ASSESSMENT:

- 11.1 The objective is to provide understanding of all the facets of dispensing activities including operations, procedures, maintenance and hazards of petroleum and the risks associated with handling of the product and training shall ensure that the jobs are performed in accordance with the laid down procedures and practices, namely: -

- (i) Every entity shall develop, implement, and maintain a written training plan to instruct all petroleum retail outlet personnel with respect to the following, namely: -
 - (a) Carrying out the emergency procedures that relate to their duties as set out in the procedure manual and providing first aid;
 - (b) Permanent maintenance, operating, and supervisory personnel with respect to the following, namely: -
 - (i) The basic operations carried out;
 - (ii) The characteristics and potential hazards of dispensing station; and
 - (iii) The methods of carrying out their duties of maintaining and operating the PRO as set out in the manual of operating, maintenance and transfer procedures;
 - (iv) Fire prevention, including familiarization with the fire control plan, fire fighting, the potential causes of fire or accident and the types, sizes, and likely consequences of a fire or accident and
 - (v) Recognizing situations when it is necessary for the person to obtain assistance in order to maintain the security.

11.2 Each oil company shall develop training module of their own which should include inter-alia of the following, namely: -

- (a) Hazardous nature of product handled;
- (b) Familiarization with operational procedures and practices;
- (c) Hands on experience on operation of equipment;
- (d) Knowledge of emergency and manual shut down systems;
- (e) Immediate and effective isolation of any spill;
- (f) Safety features and accident prevention;
- (g) Fire fighting facilities, its upkeep and operation;
- (h) Evacuation and safe egress of the vehicles in an emergency;
- (i) Housekeeping;
- (j) Decantation;
- (k) First aid;
- (l) Dos and Don'ts; and

(m) Emergency plan or drills

11.3 Records for the training and refresher courses shall be maintained.

12.0 CUSTOMER SAFETY AND AWARENESS:

12.1.1 Display of important information:

- (i) The particulars of license, emergency telephone nos. of local fire service, police and marketing company shall be conspicuously displayed; and
- (ii) Suitable caution boards or pictographs shall be displayed at areas where required.

12.2 DOs and DON'Ts during Refueling:

Dos:

- (i) Switch off the engine before commencement of refueling;
- (ii) Ensure that a 9 kg DCP fire extinguisher is available near the dispenser; and
- (iii) In case of any spill, overflow of product, fire or smoke observed, press the "EMERGENCY STOP" button on the dispenser.

DON'Ts:

- (i) Do not start the engine or drive away the vehicle till the filling nozzle has been disconnected from the filler cap of the vehicle;
- (ii) Do not refuel the vehicle during the period MS or HSD is being decanted into the tank;
- (iii) Do not smoke;
- (iv) Do not use naked flame; and
- (v) Do not operate mobile phones.

13.0 List of Standards or Guidelines referred to in Schedule 1 shall be as given in Annexure VIII.

Annexure – I
Zone classification for Retail Outlets

(A) UG Tanks and Fill Points:

Facility	Location of Hazardous Zone	Area Class
Underground storage tanks (Figure 1.1)	Within any tank and within any manhole chamber in which there are either direct or off-set fill tanker delivery hose connection points, or vapour connection points.	Zone 0
	Within any manhole chamber not containing tanker delivery hose or vapour connection points.	Zone 1
	For all tank filling connections, (including above ground off-set fill points and any vapour connection) vertically for 1.25 m above forecourt level, extending horizontally for 3 m and coning down to forecourt level at a radius of 4 m from the connections.	Zone 2

a. Fill points in manhole chamber:

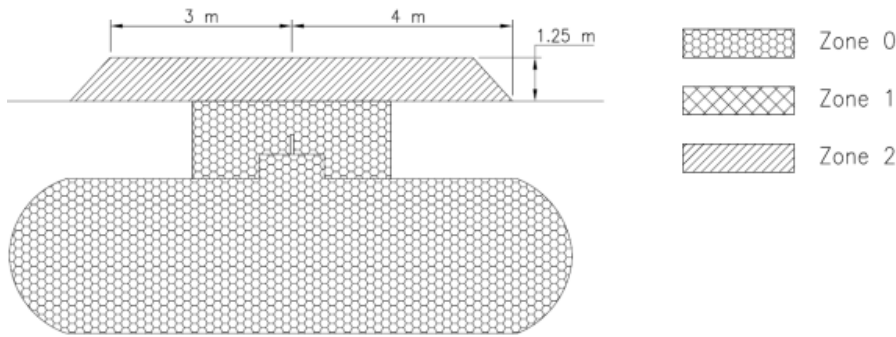

b. Offset fill points in manhole chamber:

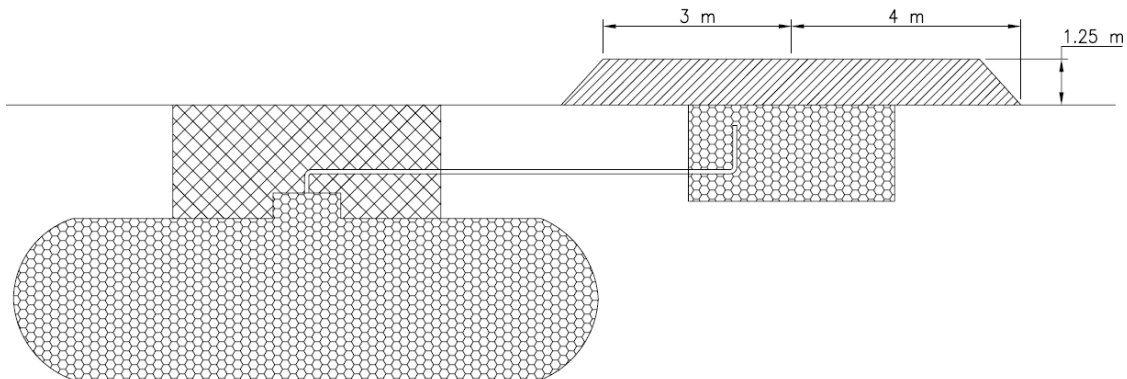

c. Above ground offset fill points:

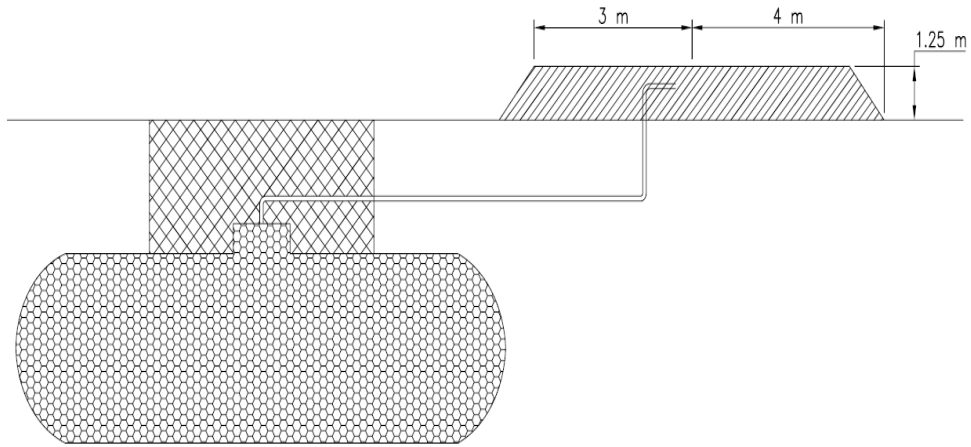
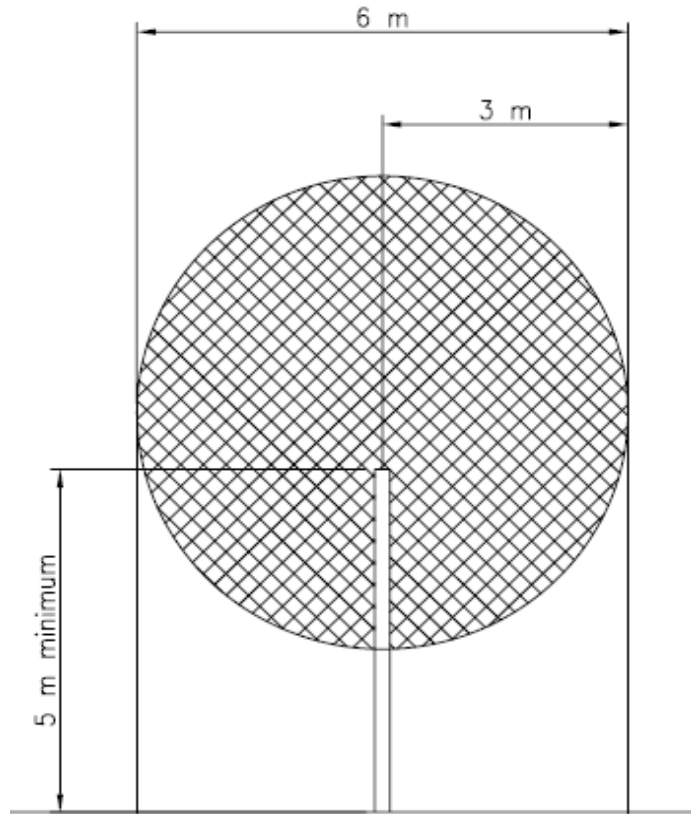

Figure 1.1 – Underground tanks

(B) Vent Pipes:

Facility	Location of Hazardous Zone	Area Class
Vent pipes for underground storage tanks (Figure 1.2)	Within a radius of 3 m in all directions of the open end of any vent pipe.	Zone 1
	The area below the Zone 1 area of the vent pipe, for a radius of 3 m around the discharge point and down to ground level.	Zone 2



Storage tank vent pipe without vapour emission control
Figure 1.2 – Vent pipes

Annexure II

Components of Retail Automation

Each of the retail automation components is described in brief in the following system architecture Diagram and paragraphs.

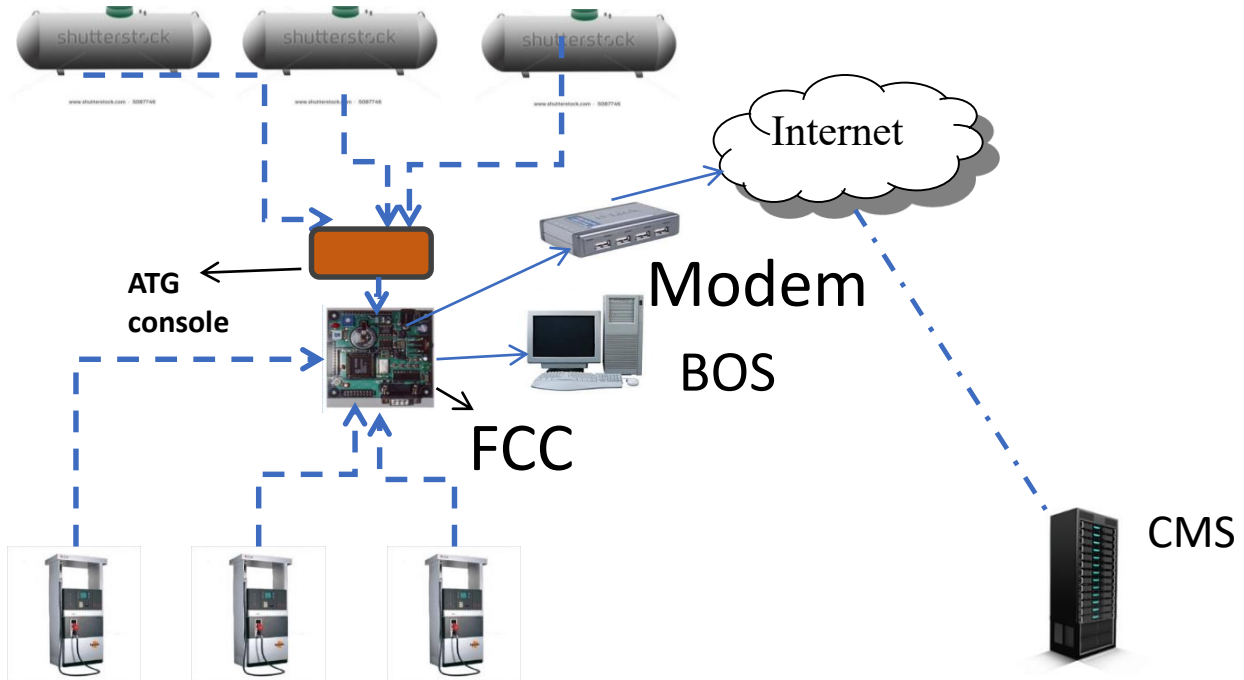

RO AUTOMATION ARCHITECTURE

1. Forecourt controller (FCC):

This is the central component of the automation system. Installed in the sales building and communicates with forecourt devices like dispensers, ATG, Price signs, Payment Terminals, and other like devices.

The communication with these devices takes place using communication or power cables or wireless connectivity.

2. Back Office:

Back office system computer or monitor provides user interface with RO automation system for staff in the sales building at the retail outlet. This is connected with Forecourt controller and works on local area network.

3. Local LAN network:

This is local TCP or IP network within the sales building to provide connectivity to various components of automation.

4. Wireless Access points:

These are installed on the sales building or on the canopy for providing wireless connectivity to various devices within the station.

5. VSAT or GPRS or Broadband Routers cum Modem:

Communication between the retail outlets and head office system using VSAT or GPRS routers. These are installed in or on the top of sales building or behind the building near the compound wall.

6. Automatic Tank Gauging System (ATG):

This system has following two main components, namely: -

(a) ATG probes: Installed inside the tank.

Probes communicate with ATG controller (installed inside the Sales Building) through cables or on wireless communication;

(b) ATG Controller: The unit is installed inside the sales building. It is capable of connecting to multiple tank probes and may have display to show the tanks status. It communicates with FCC.

The controller and probes together as full unit shall be certified for intrinsic safety.

7. Electronic Price Signs (EPS):

These are used for product price display and are installed in price pole in non-classified area. These are integrated with the forecourt controller using cables or on wireless connectivity.

8. Payment terminals:

(a) Fixed location outdoor Payment Terminals (OPT):

These units are fixed on pedestal or dispenser. The unit can take power connection taken from the independent source or from the DU power junction box using certified cable glands;

(b) Mobile payment devices:

Mobile devices may be used in the forecourt for the purpose of payments or receipt printing provided these are restricted to Zone-2 or safe area. In case they are required to be used in Zone-1, necessary certification shall be obtained; and

(c) Card Reader in Dispensers (CRIND):

These payment terminals are mounted inside the dispenser electronic section. These are factory fitted and type approved along with dispensers.

9. Receipt Printers:

These devices are independently mounted in the forecourt in safe area, connected to RO automation using cables or wireless connectivity.

10. Attendant Tag Readers:

These devices which associate the transaction to the attendant are installed on the dispenser or built into the OPT in safe area.

11. Close Circuit surveillance system (CCTV):

This system is an independent system and has following two components; namely

(a) Cameras:

Mounted on the top of building or canopy or canopy columns or on independent pedestal. Needs power and communication cables to be connected to DVR or NVR; and

(b) Digital Video Recorder (DVR) or Network Video Recorder (NVR):

Video Recorders installed in the sales building. Records the images from the various cameras.

Annexure – III

Weekly Check List

Date:

Time:

Sr. No	Particulars	Remarks
(To be carried out by individual DSM on rotational basis)		
1.	All the Dispensing Units are externally clean	Yes/No
2	Sand below dispenser unit is loose and devoid of any spillage of product or contain any inflammable waste.	Yes/No
3	All the piping connections of Dispensing units and tank farm are leak free and there is no sweating in the joints.	Yes/No
4	Wire mesh in the product vent is not choked with foreign matter.	Yes/No
5	Fire extinguishers are in place and fit for use.	Yes/No
6	Driveways and pathways are clear of any obstructions.	Yes/No
7	Safety signs are in place (No smoking, mobile phone not to be operated).	Yes/No
8	Tank farm is clean and free of dry vegetation.	Yes/No
9	The sand in the fire bucket is dry and without any lumps.	Yes/No
10	All the light fixtures at the periphery, canopy and the sales room are in working condition.	Yes/No
11	No employee of the retail outlet is in an intoxicated state.	Yes/No
12	Regular briefing [Do's and Don'ts] on safety to DSMs has been carried out.	Yes/No
13	General house-keeping is good.	Yes/No
14	There are no electrical loose connections observed in and around the fore court area.	Yes/No
15	Any other unsafe condition.	Yes/No

Annexure –IV
System Document for Electrical Safety Audit

Sl. No.	Item	Observation	Action Needed
A. Deviation from laid down procedure:			
1.	Deviation from statutory Requirements as laid down. in the law in force relating to electricity and petroleum		Immediate attention needed to rectify the issue and comply with statutory requirements
1.1	Equipments enclosure mismatch with corresponding zone of application		Equipment with appropriate enclosure, to be installed.
1.2	Clearances not maintained as per guideline		Minimum clearance to be ensured.
1.3	Material not as per respective Indian Standards		Replaced with IS approved materials.
1.4	Inappropriate illumination levels		Modify to meet the recommendation.
B. Insulation, Grounding and Lightning Protection:			
2.	Grounding and Lightning Protection Systems are not as per IS-3043 and IS -2309		
2.1	Electrical equipments are not earthed as per the recommendation		“Earth” connection to be provided as per recommendation
2.2	Neutral point of transformer and DG set are not earthed		“Neutral” points have to be grounded as per recommendation
2.3	The lightning or surge arrestors are in not in place and/or not connected to earth, or both		Lightning or surge arrestor to be properly placed and connected
2.4	High Earth Resistance		Salt and water to be added to earth pit to reduce earth resistance.
2.5	Insulation resistance low, less than 1 Mega Ohm		Damaged portion of insulation to be repaired, insulation resistance to be beyond 1 Mega Ohm.
2.6	All panel doors are not earthed with flexible braided connection		Missing flexible earth links to be put at the earliest.

2.7	The electrical room is not clean, and there is water accumulation inside the room or cable trenches		Room to be cleaned, water wiped out, all holes for water entry, to be blocked.
C. Protection and Metering System:			
3	Protection System is not operating		
3.1	Emergency push button jammed		Push button to be replaced, safety checked by simulation
3.2	Under-voltage, over-voltage, phase unbalance protection not working		Relay to be properly set and fault condition to be simulated to check and ensure healthiness of the protection system.
3.3	Neutral snap, phase failure protection not working		
3.4	Meters not indicating or recording properly		Meter, its C.T. and P.T., as required, to be replaced immediately.
D. Loose connection and overheating:			
4.1	Loose connection in cable termination		Termination to be tightened properly
4.2	Equipments running in overload condition, heating and burning smell		Load must be restricted within the design limits, loose connection, if any, shall be set right.
E. Safety:			
5.1	Non-functioning of lighting fixtures, especially in critical zones viz. near the dispenser, tank farm area, front and rear of sales room, electrical room		Lighting fixtures and its associated circuits to be checked and rectified.
5.2	Safety equipments, viz. rubber mat, CO2 fire extinguisher, shock treatment chart, flameproof torch are not in designated places		To be put at their designated places immediately and persons trained on procedure for shock treatment

5.3	Repairing work being carried out without any authorized work-permit		Immediately work authorization procedure to be implemented
5.4	Components material used are of poor sub-standard quality		Standard good quality components to be used
5.5	Labels or tag-marking or ferruling on equipments, cables, feeders, cable cores are missing		Missing labels or tag-marks or ferrules to be put as per drawing.
5.6	Drawing or documents not available in panels		Drawing or documents to be kept in the dedicated pockets in panels
F. Repair and Maintenance:			
6.1	Dirt and dust accumulation inside panel		Clean periodically.
6.2	Spare holes in electrical panel		Spare holes to be blocked.

ANNEXURE- V

Safety Audit Checklist

S. No.	Item	Observation	Recommendation
1	Statutory Requirements:		
1.1	Is CCOE License and Drawing at the site available?		
1.1.1	Validity and date of renewal		
1.2	Does the drawing correctly reflect existing facilities?		
1.3	Are safety message like Telephone. No., police, fire brigade, hospital and no smoking, T/L under decantation and explosive licence No. displayed?		
1.4	Is extract of explosives rules exhibited?		
1.5	Is 1 No. of DCP types (9 Kg fire extinguishers per dispenser (as applicable) provided?		
1.5.1	Last. Date of charging.		
1.6	Are fire buckets (9 ltr. Capacity) having round bottom (max 10 nos.) and cover contain dry sand?		
1.7	Last date of W and M verifications.		
2	General:		
2.1	Are the good housekeeping practices (e.g. provision of dustbin, garbage disposal or cotton waste disposal, cleaning of drainage) being observed?		
3	Tanks:		
3.1	Is the dip rod floating?		
3.2	Are the fill pipe threads corresponding to the standard size 75 mm diameter as		

	carried by tank lorries calling at the site?		
3.3	Is the vent pipe located as per the approved drawing?		
3.4	Is the wire gauge of the vent cap: (a) Missing? (b) Clogged?		
3.5	Is the manhole chamber free of: (a) Rubbish (i.e. cotton waste or rags and like other rubbish) (b) Oil Spillage		
3.6	Are tank curb walls or pipe railings in good condition?		
3.7	Are lorry discharge points distinctively painted as per our standard?		
3.8	Are the following securely closed: (a) Lorry discharge points? (b) Dip pipe?		
3.9	Are sank buckets and fire extinguishers positioned near the T/L during T/L unloading?		
3.10	Is bonding wire connected while decanting the tank lorry?		
4	Pumps:		
4.1	Are the pumps: (a) Clean? (b) Leaky?		
4.2	Are the electric motors properly earthed? (a) Located as per the drawing? (b) Easily accessible?		
4.3	Is there any loose wiring in the pump?		

4.4	Are flameproof boxes closed properly?		
4.5	Is dry sand filled in the gap below pump in pump pedestal?		
5	Building and other facilities:		
5.1	Are any other flammable materials like LPG cylinders, cardboard cartons and like other flammable materials., are stored in the generator room?		
5.2	Whether generator room properly ventilated, clean and dry?		
6	Electrical:		
6.1	Is the electrical system as per our standard?		
6.2	Is there any loose wiring in the switch board?		
6.3	Is the earthing provided as per new standards?		
6.4	Are the light fixtures in good condition?		
6.5	Are the cables with FLP glands fitted to pumps?		
6.6	Are all the equipments a labeled?		
6.7	Are all the cable or wire terminations tightened?		
6.8	Is there any dirt or dust inside the electrical panels?		
6.9	Are all spare cable entry holes in all electrical panels blocked?		
6.10	All panel doors are earthed with flexible braided connection?		
6.11	Are all electrical equipments earthed as per recommendations?		
6.12	Are Neutral point of transformer and DG set earthed?		
6.13	The lightning or surge arrestors are in place and in		

	working condition and are connected to earth?		
6.14	Is the insulation resistance of each feeder is more than 1 Mega Ohm?		
6.15	Is the voltage between the neutral and earth limited to 3V?		
6.16	Is the electrical room maintained clean, free from water accumulation?		
6.17	Is there any undue heating in any parts of any equipment?		
6.18	Is the shock treatment chart is available in electrical room and all concerned persons are trained on the treatment procedures?		
7	Tank Lorry:		
7.1	Is the earth wire connected properly during decantation?		
7.2	Is fire extinguisher available?		
7.3	Is the fire extinguisher kept accessible?		
7.4	Is PCVO crew aware of fire fighting methods?		
7.5	Is dip pipe kept closed while decanting?		

ANNEXURE – VI (A)

WORK PERMIT (For issue by RO Manager or Operator or Dealer)

(NAME OF COMPANY)

NAME OF THE RO or LOCATION

Sl. No _____

_____ / _____

DATE AM / PM

DATE AM / PM

VALID FROM _____

UPTO _____

PERMISSION IS GRANTED TO
SECTION or CONTRACTOR _____

NAME _____

NATURE OF WORK IN DETAIL FOR WHICH THIS WORK PERMIT IS VALID

LOCATION OF WORK (Specific area inside the RO) – -----

THE FOLLOWING ITEMS SHALL BE CHECKED BEFORE ISSUING THE PERMIT
(Please put tick [] mark in the appropriate box)

Sr. No	Item	Done	Not required
1.	Equipment or Work Area inspected	[]	[]
2.	Surrounding area checked, cleaned and covered (ensuring product is not exposed to atmosphere in the working area)	[]	[]
3.	Identify the equipment to be repaired and switch off its electric supply	[]	[]
4.	Portable extinguisher and sand buckets provided	[]	[]

5. Blocking of sources of product or vapour in pipeline or tank or equipment [] []

SPECIAL INSTRUCTIONS

1. Following personal protective equipment are required (check all items required)
Safety helmet or safety gloves or protective goggles or safety shoes or safety belt
2. In case of fire alert, all work must be stopped. All personnel must leave work site and proceed to designated or on site directed areas.
3. Remarks on toxic or hazardous chemicals, if any (Eg., sludge, oil spillage or like other toxic or hazardous chemicals)

4. Alternate means of escape available or provided/not required.
5. This permit must be available at work site at all times.
6. Additional items, if any:

Name and _____ Name and _____

Signature of Issuer _____ Signature of Receiver _____

Permit closed at hrs

Name and _____ Name and _____

Signature of Issuer _____ Signature of Contractor _____

Typical list of activities for which permit annexure VI (A) to be filled:

- (a) Access into a building or canopy roof.
- (b) Access into a building canopy cavity.
- (c) Electrical switch board work.
- (d) Excavation including forecourts up to 1 metre depth
- (e) Forecourt surface repair.

- (f) Water removal from underground tank through hand pump
- (g) Repair of electrical and electronic equipments inside hazardous area (operation of all electrical and electronic instruments inside hazardous areas, unless certified intrinsically safe)
- (h) Promotional activities on forecourts.
- (i) Signage, including canopy signage or lighting works
- (j) Replacement or installation of dispensing units.

ANNEXURE-VI (B)

WORK PERMIT (For issue by officer of the oil company)

(NAME OF COMPANY)

NAME OF THE RO or LOCATION

Sl. No. _____

_____ / _____

VALID FROM _____ DATE _____ AM/PM

UPTO _____ DATE _____ AM/PM

Note: THIS PERMIT SHALL BE VALID FOR THE ABOVE SPECIFIED PERIOD NOT EXCEEDING 45 DAYS

PERMISSION IS GRANTED TO SECTION or CONTRACTOR

NAME _____

NATURE OF WORK IN DETAIL FOR WHICH THIS WORK PERMIT IS VALID

LOCATION OF WORK (Specific area inside the RO) -

THE FOLLOWING ITEMS SHALL BE CHECKED BEFORE ISSUING THE PERMIT

(Please put tick [] mark in the appropriate box)

Sr. No	Item	Done	Not required
1.	Equipment or Work Area inspected	[]	[]
2.	Surrounding area checked, cleaned and covered (ensuring product is not exposed to atmosphere in the working area)	[]	[]
3.	Identify the Equipment to be repaired and switch off its electric supply		

	(equipment electrically isolated and tagged)	[]	[]
4.	Portable extinguisher and sand buckets provided	[]	[]
5.	Blocking of sources of product or product vapour of pipeline or tank equipment (Equipment blinded or disconnected or closed or isolated or wedge opened)	[]	[]
6.	Removal of left over product in tank or pipeline or equipment taken up for works	[]	[]
7.	Equipment water flushed	[]	[]
8.	Pyrophoric Iron removed or kept wet	[]	[]
9.	Proper ventilation and lighting provided	[]	[]
10.	Gas test done, found gas free	[]	[]
11.	Standby personnel provided (confined space entry viz tank entry and like other entries)	[]	[]

SPECIAL INSTRUCTIONS

1. Following personal protective equipment are required (check all items required):
safety helmet or safety gloves or protective goggles or safety shoes or safety belt
2. In case of fire alert, all work must be stopped. All personnel must leave work site and proceed to designated or on site directed areas.
3. Remarks on toxic or hazardous chemicals, if any.

4. Alternate means of escape available or provided or not required.
5. This permit must be available at work site at all times.
6. Additional items, if any:

I have duly explained the nature of the work, risk involved and all the safety precautions to be followed to the vendor and his supervisor for implementation, as well as to the dealer and his authorized representative for monitoring the same. This permit shall be valid till the work as mentioned in “Nature of work” is completed.

Name and _____
Signature of Officer _____

I have understood the risk involved and the safety precautions explained to me by the oil company officer and I shall monitor the work in accordance with the same till the work as specified under the “Nature of Work” is completed.

Name and _____
Signature of dealer or authorised manager _____

I have understood the risk involved and the safety precautions explained to me by the oil company officer and I shall carry out the work in accordance with the same, till the work as specified under the “Nature of Work” is completed.

Name and _____
Signature of contractor or authorised supervisor _____

List of activities for which permit annexure vi (b) to be filled:

- (a) Repair or rework or cleaning on the tanks and pipeline work
- (b) Tank removal or decommissioning.
- (c) Non-routine maintenance or replacement or major electrical work within hazardous area.
- (d) Oxygen deficiency or inert gas entry.
- (e) Pneumatic or hydrostatic pressure testing.
- (f) Oil interceptor (like oil or water separator and like other interceptor) cleaning – where entry into the interceptor is required.
- (g) Hot work including but not limited to welding or grinding or gas cutting.
- (h) Demolition or revamping.
- (i) All activities capable of producing a spark inside a hazardous area.
- (j) Excavation including forecourts exceeding 1 metre depth.
- (k) Concrete cutting in the hazardous Zone.
- (l) Setting up of temporary equipment including product recovery equipment E.g. compressor, water or sand blasting equipment and like other equipment.

ANNEXURE - VII

Safety Checklist for Tank-Truck Decanting at Retail Outlet

Sr. No	Activity Check
1	Only one tank-truck is being decanted at the retail outlet at a given time.
2	Tank truck to be positioned in the demarcated area and area to be cordoned off.
3	Ensure no ignition source in the vicinity of the tanker.
4	Tank-truck has CCOE-approved spark arrestor.
5	Parking brakes and gear must be engaged at all times. Place wheel chokes to prevent movement of tanker.
6	The engine of the tank-truck has been switched off and the battery switch is in 'off' position.
7	'No Smoking' board is displayed prominently.
8	Ensure connecting the TT to the earthing bus and proper bonding prior to any decantation action.
	Ensure leakproof coupling on the hoses both on tank side and tanker side.
9	Dip pipe of the underground tank opening has been kept closed to avoid any vapour accumulation during decantation
10	The engine of the tank-truck has been switched off and the battery switch is in 'off' position.
11	Mobile phones of the tank-truck crew and the retail outlet staff assisting them have been switched off or Mobile phone should not be operated.
12	The 10 kg or 9kg DCP fire-extinguisher of the tank truck has been taken out and kept next to the tank-truck.
13	Fire buckets are easily accessible.
15	Ensure rubber hose with external continuity wire and suitable end coupling only is being used.
16	Only bonded metallic bucket is being used for drawing samples.
17	The driver, khalasi and the designated retail outlet supervisor are present during the entire process of decantation.

Verified that all precautions have been taken with regard to decantation as detailed above.

(Signature and
Name of Driver)

Signature and
(Name or Designation of authorized RO staff)

Annexure – VIII

REFERENCES

- (i) Petroleum Rules – 2002.
- (ii) Marketing Discipline Guidelines.
- (iii) IS 2062: Steel for General Structural Purpose.
- (iv) IS 1239: Part 1: and IS 1239: Part 2: Steel Tubes and Other Wrought Steel Fittings.
- (v) IS-5572: Hazardous Area Classification.
- (vi) IS 10987: Code of Practice for Design, Fabrication, Testing and Installation of Underground / Above ground Horizontal Cylindrical Storage Tanks for Petroleum Products.
- (vii) IS 2309: Code of Practice for the Protection of Building and Allied Structures Against Lighting.
- (viii) IS 3043: Code of Practice for Earthing.
- (ix) UL 1316: Glass-Fiber-Reinforced Plastic Underground Storage Tanks for Petroleum Products, Alcohols, and Alcohol-Gasoline Mixtures.
- (x) UL 971: Nonmetallic Underground Piping for Flammable Liquids.
- (xi) EN 14125: Thermoplastic and Flexible Metal Pipe Work for Underground Installation at Petrol Filling Station.
- (xii) IS-1978: Indian Standard Specification for Line Pipe.
- (xiii) UL 87- Power Operated Dispensing Device for Petroleum Product or Relevant Standards.
- (xiv) UL 79- Power Operated Pumps for Petroleum Dispensing Products or Relevant Standards.
- (xv) IS: 5571 - Guide for selection and installation of Electrical equipment in hazardous areas.

SCHEDULE 2
[See regulation 6(2)]

STORAGE, HANDLING AND DISPENSING AT AUTO LPG DISPENSING STATIONS

1.0 SCOPE:

The technical standard and specifications including safety standards under this Schedule lay down the minimum requirements in design, operation, inspection, maintenance, training, consumer safety at auto LPG dispensing stations (ALDS) and do not cover the certification or fitness requirements of vehicles using auto LPG.

2.0 DEFINITIONS:

In these regulations, unless the context otherwise requires,

- (a) “Auto LPG” means a mixture of certain light hydrocarbons derived from petroleum, which are gaseous at normal ambient temperature and atmospheric pressure but may be condensed to liquid state at normal ambient temperature by the application of moderate pressure, and which conforms to IS :14861;
- (b) “Auto LPG Dispensing Station (ALDS)” means the premises used for storing and dispensing auto LPG to the motor vehicles for automotive purpose;
- (c) “Auto LPG Tank” means a steel container for storage and transport of Auto LPG, fitted permanently in a motor vehicle or vehicle as its fuel tank, for automotive fuel and filled in that position and conforming to IS:14899 and as approved by the Petroleum and Explosives Safety Organisation under Gas Cylinder Rules, 1981;
- (d) “Auto LPG Tank Truck” means a truck mounted with a properly designed vessel/tank for transportation of auto LPG in bulk to the dispensing stations;
- (e) “Bob tail” means a truck mounted with a properly designed vessel or tank with flowmeter pump skid for transportation of LPG in bulk to the dispensing stations.
- (f) “Bulk storage” means the facilities for storing LPG in stationary pressure vessels exceeding the capacity of 1000 Lt and these pressure vessels shall conform to the Static & Mobile Pressure Vessels (Unfired) Rules, 1981.
- (g) “Dispenser” means the equipment provided in the ALDS for delivering LPG to the Auto LPG Tank of motor vehicles;
- (h) “Emergency shut off valve” means a shut off valve which, in an emergency, operates automatically or can be operated remotely;
- (i) “Filling Point” means the point of inlet pipe connection of a bulk storage tank for MS or HSD or LPG, where hose is connected for filling the products into the tank;

- (j) “LPG Tank Truck Unloading Hard Stand” means the area specially prepared in a Auto LPG Dispensing Station beside the LPG fill point for unloading from tank truck to bulk storage vessel;
- (k) “LPG vent” means the vertical pipe provided on the vessel for discharge of LPG vapours from safety relief valve at a height of at least 2 meters above the top level of the vessels but not less than 3 meters from the ground level;
- (l) “MS or HSD Vent” means the vertical pipe open at the top, fitted on an underground tank in retail outlets for breathing;
- (m) “Retail Outlet or MS or HSD Service Station” means the segregated area provided with facilities and specially prepared, for storage and delivering MS or HSD to the fuel tanks of motor vehicles; and
- (n) “Safety Relief Valve” means a pressure relief device fitted on a pressure vessel to protect the vessel against maximum allowable pressure;

3.0 LAYOUT AND FACILITIES:

3.1 General Guidelines:

- (i) The layout should ensure unobstructed movement of all vehicles together with adequate provision for entry and exit of Tank trucks;
- (ii) Location of the facilities, equipment, entrance, exit and paving shall be arranged in a such manner to avoid the risk of any collision amongst the motor vehicles;
- (iii) The fuel lines shall have a positive segregation with electrical cables;
- (iv) It is preferable that there should be unobstructed view of the operating and dispensing areas from the salesroom;
- (v) Access for mobile fire fighting equipment to all the ALDS facilities shall be ensured;
- (vi) In case of above ground bulk storage vessels, provision of storage of adequate fire water shall be made;
- (vii) Provision of escape route for personnel and vehicle in emergency shall be made; and
- (viii) The LPG bulk storage area at ALDS shall be enclosed by an industrial type fencing at least 2 M high erected on a kerb or toe wall of at least 0.3 M high and fill point shall be at the inner edge of this fencing and such area shall be suitably guarded against vehicular impact. Such fence shall have at least two means of exit and the gates of such exits shall open outwards and shall not be self-locking.

3.2 Siting and Layout:

ALDS may be located in an existing petroleum retail outlet station. Safety distances to be followed are given in the table 1 and 2 below:

TABLE - 1

Safety distances for bulk LPG storage vessels

Serial No.	Water Capacity of vessel (in litres)	Minimum distance from line of adjoining property or group of buildings not associated with storage and operation. (in metre)		Minimum distance between vessels (in metre)	
		Above ground vessel	Underground or above ground vessels covered with earth (mound)	Above ground vessel	Under ground or above ground vessels covered with earth (mound)
(1)	Not above 2000	5	3	1	1
(2)	above 2000 but not above 7500	10	3	1	1
(3)	Above 7500 but not above 10000	10	5	1	1
(4)	Above 10000 but not above 20000	15	7.5	1.5	1
(5)	Above 20000 but not above 40000	20	10	2	1

TABLE – 2

Minimum Safety Distances (in meters) between facilities associated with storage and dispensing of LPG in ALDS

S. No.	To from	LPG storage vessels	Fill point of LPG storage vessel and centre of LPG tank truck unloading hard stand	LPG Dispenser	Property Line / buildings*	Petroleum class A or B service station licensed		
						Fill point of petroleum class A or B tanks	Vent pipe of petroleum class A or B tanks	Petroleum class A or B dispensing pump

1	LPG storage vessels	As specified in Table -1	9 (above ground or mounded vessels exceeding 7500 litres capacity)	9 (above ground vessels not exceeding 20000 litres capacity or underground or mounded vessels)	As specified in Table 1	9	9	9
			6 (above ground or mounded vessels not exceeding 7500 litres capacity)	15 (above ground vessels exceeding 20000 litres capacity)				
			3 (underground vessels)					
2	Fill point of LPG storage vessel and centre of LPG tank truck unloading hard stand	9 (above ground or mounded vessels exceeding 7500 litres capacity)	-	6	9	6	6	6
			6 (above ground or mounded vessels not exceeding 7500 litres capacity)					
			3 (underground vessels)					

3	LPG dispenser	9 (above ground or mounded vessels exceeding 20000 litres capacity or underground or mounded vessels)	6	-	6	6	6	6
		15 (above ground or mounded vessels exceeding 20000 litres capacity)						
4	Property line/buildings*	As specified in Table - 1	9	6	-	3	4	6

* The distance of sales room shall be maintained as specified by Petroleum and Explosives Safety Organisation.

Notes:

- (i) If the aggregate water capacity of a multi vessel installation exceeds 40 KL, the minimum safety distance from any vessel to the property line or group of buildings shall not be less than 30 m for above ground vessels and 15 m for underground vessels;
- (ii) The distances specified in clause (i) are required to be measured from the nearest point on the periphery of the vessel;
- (iii) Minimum 6 m distance shall be kept between LPG bulk storage vessel and Storage vessel of the other petroleum products and
- (iv) Typical layout of installation is specified in as annexure – I.

3.2 Bulk Storage Vessel:

- i. The mechanical design of the storage vessel shall be based on following considerations, namely: -

- (a) The storage vessel shall be designed in accordance with the codes i.e. PD – 5500, ASME-Sec VIII, IS:2825 or equivalent duly approved by PESO. Design shall also take into account the requirements specified in Static and Mobile Pressure Vessels (Unfired) Rules, 1981;
- (b) A single code shall be adopted for design, fabrication, inspection and testing i.e. ASTM and BS shall not be combined;
- (c) Material: Carbon steel conforming to ASTM A516 Grade 60 / 70 or A537 Class I. Micro-alloyed steel containing Ni, Mo, Va shall not be considered. Maximum specified tensile stress of the material shall be below 80,000 psi;
- (d) Design Temperature: -27 °C to +55 °C;
- (e) Design Pressure: Maximum Vapour pressure of LPG conforming to IS: 14861 at 55 °C and shall be taken as 14.5 kg/cm²;
- (f) Other Design Considerations:
 - (i) Corrosion Allowance: 1.5 mm (minimum);
 - (ii) Radiography: 100 %;
 - (iii) Stress relieving: 100% irrespective of thickness;
 - (iv) Wind pressure: as per IS: 875;
 - (v) Earthquake pressure: as per IS:1893;
 - (vi) Hydrotest pressure: As per design code and
 - (vii) Additional requirement, if any, on account of design codes or statutory stipulations shall also be considered.

3.3.1 Above Ground Storage Vessel:

- (i) The bulk storage vessel shall be placed on a firm foundation;
- (ii) There shall be single nozzle at the bottom for liquid inlet or outlet with ROV as first valve. The first flange shall be at least 3 m away from the shadow of the vessel;
- (iii) In multi vessel installation, top of the vessels shall be in the same plane, and
- (iv) Suitable arrangement for draining of water from storage vessel shall be provided with double valve.

3.3.2 Mounded or Underground Storage Vessel:

Mounded or Underground storage vessels shall also conform to the following requirements, namely;

- (i) The specific consideration shall be given to
 - (a) Internal vapour and hydraulic pressure
 - (b) External loading on the vessel; and
 - (c) Internal vacuum;
- (ii) The dimensions (diameter and length) of the vessel shall be decided based on site conditions, soil mechanics and other design considerations;
- (iii) The vessel shall be protected against corrosion by appropriate anti corrosive coating and provided with cathodic protection. Alternatively, steel tank can be designed for the service life and shall be taken out of service on completion of design service life with periodic inspections to verify the veracity of design parameters;
- (iv) The cathodically protected pipelines or vessels or other like things shall be isolated from the unprotected structures or surfaces;
- (v) Reference points on inner surface of the vessel shall be marked for non-destructive testing for subsequent inspections;
- (vi) The underground vessel shall be installed on a firm foundation and firmly secured to the foundation so as to prevent movement or floatation;
- (vii) The underground vessel shall be placed within a concrete or brick masonry pit with a minimum gap of 1 m between the walls of the pit and the vessel as well as in between the vessel;
- (viii) The vessels shall be covered by earth or sand or any other non-corrosive material and thickness of the covering material above the top surface of the vessel shall not be less than 0.5 m; and
- (ix) The fittings or mountings on the vessel shall be in such a way that these can be operated and maintained without disturbing the earth cover.

3.4 Fittings:

Each storage vessel shall have at least two safety relief valves, two independent level indicating devices, one independent high level or cut off switch with alarm, temperature gauge, pressure gauge, suitable arrangement for water draining and other like fittings Remote operated valve (ROV) shall be provided on all liquid and vapour lines connected to the storage vessel.

3.4.1 Safety Relief Valve:

- (i) Each safety relief valve shall be set to discharge at not more than 110 % of design pressure and have relieving capacity adequate to prevent the maximum pressure in the vessel from exceeding 120 % of the design pressure. Each safety relief valve shall be provided with a lock open type isolation valve between it and the vessel so that one of the two valves can be removed from testing without emptying the vessel.
- (ii) The set and reset pressure of the safety valve shall meet the requirements of Auto LPG conforming to IS: 14861; and
- (iii) The relieving capacity of the safety valve storing LPG in mounded and underground storage vessel shall be at least 30 % of that for above ground storage vessel in fire condition.

3.4.2 Emergency Shut off Valve i.e. Remote Operated Valves:

- (i) Emergency shut off valves of remote operated type shall be provided on all liquid and vapour connections i.e. filling, discharge, pump by pass and vapour return lines of the bulk storage vessels except those for safety valves or instruments tapping and those not exceeding 3 mm diameter for liquid and 8 mm diameter for vapour. ROV's shall be operable from sales room or control panel and from operating area;
- (ii) The remote operated valves shall be fire safe valves with a closing time not exceeding 15 seconds;
- (iii) ROV's shall have an open or closed position indicator; and
- (iv) Additionally, isolation valves of ball type shall be installed at shortest distance from ROV.

3.4.3 Excess flow check valves (EFCV):

- (i) Excess flow check valve shall be provided on the liquid lines. The closing flow of the EFCV shall not be more than 120 % of the rated flow of the line or as recommended by the manufacturer. Excess flow check valve shall be provided with a breathing arrangement to allow equalisation of pressure; and
- (ii) In closed position, the opening of the EFCV shall not be more than 2 mm².

3.4.4 Manual Shut Off Valves:

Manual shut off valves shall be provided in all liquid and vapour pipelines as close to ROV as possible. All shut off and isolation valves shall be of quick closing ball type, readily accessible for operation and maintenance under normal and emergency conditions.

3.5 Tank Truck Unloading Facilities:

- (i) The layout of the unloading location shall be such that tank truck being unloaded shall be in drive out position;
- (ii) Suitable provision shall be made for evacuation of LPG from bulk storage vessels to tank truck to empty the vessel in case of emergency or for statutory testing
- (iii) Tank truck shall be unloaded using hose with the breakaway coupling with isolation arrangement on both ends so that no release of liquid LPG take place at the end of the unloading. Alternatively, loading arms can be provided;
- (iv) The hose - coupling or flange joint shall be of 300 lb rating with metallic gasket. The hose coupling shall be provided with a cap or blind flange by which the nozzle can be closed when not in use;
- (v) The LPG hose used shall conform to Indian standard or API or EN codes;
- (vi) Hose length shall not be more than 5.5 m;
- (vii) The pipeline and the hose shall be laid so as to be above the ground to prevent any damage. The entire assembly shall be suitable supported and be installed in a lockable enclosure;
- (viii) The fill point shall be provided with non-return valve and quick shut off isolation valve;
- (ix) Proper arrangement for earthing and bonding shall be made; and
- (x) The vent pipe, if required, shall be at height of at least 3 m from the grade and 6 m away from potential sources of ignition or likely places of vapour accumulation.

3.6 LPG Pump:

LPG pump can be either external or submerged.

3.6.1 External LPG Pump:

- (i) Each pump shall have suitable arrangement for weather protection as per manufacturers recommendations;
- (ii) Pump and motor shall be effectively earthed;
- (iii) Pumps shall be provided with arrangement to protect the pump casing from over pressure when pumping against a closed discharge. The bypass shall discharge into the LPG storage vessel at predetermined pressure; and
- (iv) The maximum discharge pressure of the pump (shut off pressure) shall be less than the design pressure of the piping system.

3.6.2 Submersible Pump:

- (i) Pump shall be installed in properly designed well;

- (ii) Design shall be based on combined load of pump, vessel and forces generated by operation;
- (iii) Design shall be such that installation and removal of the pump can be done at any level of LPG in the storage vessel;
- (iv) Suitable arrangement for closing the flow of LPG from vessel to pump well shall be provided;
- (v) No LPG shall escape outside from the conduit or well during normal operation, maintenance or sudden breakdown of any component;
- (vi) Provision of purging the well or pump with nitrogen for complete gas freeing, prior to removal of pump cover plate, shall be provided;
- (vii) Provision of a pressure gauge shall be made at the discharge line of the pump;
- (viii) Piping connections on well cover shall be provided with excess flow check valve;
- (ix) Pump shall have in built safety interlock to stop automatically in the event of low level, high temperature and dry condition; and
- (x) Motor should be suitable for usage as per hazardous area classification.

3.7 Dispenser:

- (i) The dispenser for Auto LPG Dispensing Stations shall be designed, constructed, tested and maintained in accordance with the requirements laid down in SMPV Rules (unfired), 1981;
- (ii) The dispenser shall be provided with an excess flow check valve, a remote operated shut off valve and a pipe shear provision in that order in the liquid inlet pipe;
- (iii) The dispenser shall be installed on a firm foundation and protected against physical damage;
- (iv) A breakaway device with excess flow valves or quick action cut off valves on both sides of the breakaway device, conforming to UL 567 or equivalent shall be provided on the delivery line from the dispenser so as to prevent spillage of liquefied petroleum gas from both sides of the breakaway point in the event of its breakage;
- (v) The dispensing nozzle at the end of the hose shall be of self-sealing type matching with filler connection of multifunction valve conforming to IS: 15100, fitted on the Auto LPG Tank of the vehicle. The liquid released on disconnection shall not exceed 5 ml;
- (vi) The hose for delivery of liquefied petroleum gas by the dispenser to motor vehicles shall be suitable for Auto LPG. The design pressure of the hose shall be minimum 25 kg/cm² with a safety factor of five. The hose shall be electrically and mechanically continuous;
- (vii) The length of the hose connected to the dispenser shall be kept minimum keeping in view the operational requirement and shall not in any case exceed 5.5 m;

- (viii) Clearly identified emergency shut down switches or circuit breakers shall be provided at easily accessible location not less than 6 m away from the dispenser to cut off power supply in the event of fire, accident or other emergency. The switches or circuit breakers shall be visible from point of dispensing liquefied petroleum gas to motor vehicles;
- (ix) Flexible hoses shall have permanent markings indicating the manufacturer's name or identification, applicable code, working pressures and suitability of use with LPG;
- (x) Provisions shall be kept to stop all operations simultaneously through push buttons located near dispenser or sales room;
- (xi) Means shall be provided on the outside of the dispenser to readily shut off the power in the event of fire or accident; and
- (xii) An excess flow check valve, or an emergency shut off valve shall be installed before the connection of dispensing hose. A differential pressure valve shall be considered as meeting this provision.

3.8 Automation:

The provisions as detailed in paragraph 5.0 of Schedule – I shall be complied with.

3.8 Piping:

- (i) All metallic piping for LPG service shall be rated and designed to ASME-B-31.3 or equivalent with minimum design pressure 25 kg/ cm² with a factor of safety of four. The materials of pipe shall be low carbon or alloy steel conforming to American Standard ASTM-SA-333 grade 6, or SA-106 grade B Schedule 40 (for above ground) and Schedule 80 (for underground), or equivalent. The pipeline shall be tested at one and half times of the design pressure, if hydro tested, or ten percent in excess of the design pressure if pneumatically tested. Joints of pipeline above 40 mm diameter shall be welded or flanged. Threaded or screwed connection shall not be provided except for special fittings like excess flow valve, pump connections upto 50 mm diameter;
- (ii) Piping shall be protected against physical damage, collision and corrosion;
- (iii) Pipe length shall be short and diameter shall be kept as small as practicable;
- (iv) Entire piping system including the appurtenances shall wherever possible be constructed with welded joints and where necessary with flanged joints. The number of flanged joints shall be kept down to a minimum;
- (v) Piping shall be run as directly as practical from one point to another and with as few restrictions such as elbows and bends as conditions will permit;
- (vi) Provision shall be made in the piping including connection to the bulk storage vessel to compensate for expansion, contraction, jarring, and vibration;

- (vii) Wherever threaded joints are used, a seal weld shall be provided. All threaded joints and socket weld pipe fittings shall be rated at least 3000 lb to BS 3799 or at pressure class 3000 to ASME B 16.5 or equivalent;
- (viii) All gaskets shall be of flexi-metallic type. Whenever a flange is opened gasket shall be replaced;
- (ix) All flanged joints shall be rated at least class 300 to BS 1560: part 2 or ASME: B: 16.5 or equivalent;
- (x) Flexible piping connections shall be introduced into fixed piping systems wherever it is necessary to absorb vibration or where a rigid connection is impractical. Flexible connections shall be short and not exceed 500 mm in length and shall be of an approved metallic construction suitable for auto LPG service and braided on outside with stainless steel wire. The design parameters for flexible piping connections shall be identical to other piping network. The non - metallic pipe, tubing or hose for permanently interconnecting storage vessels shall not be used;
- (xi) All sections of pipe in which LPG liquid can be trapped by the closing of the valves shall be fitted with thermal safety valves and shall be located in fenced area; and
- (xii) Upon mechanical completion of the ALDS, a complete set of as built installation drawings shall be maintained.

3.9 Control Panel:

- (i) A remotely located and easily accessible control panel for normal operations shall be installed preferably at the sales room. It shall have provisions and indications of on or off, low pressure of instrument air, high temperature trip of LPG pumps and quantity of product in the vessel. It shall also have an alarm and indication for high level cut off. All indications connected with emergency shut off switch shall be provided on this control panel along with and "Reset" provisions;
- (ii) Piping and Instrumentation Diagram (P and ID) of entire LPG system shall be displayed near the control panel. (Typical P and ID is specified Annexure – II); and
- (iii) All switches shall be clearly marked for its purpose in the field.

3.11 Electrical Equipment or Fittings:

The electrical equipment and fittings in ALDS shall conform to hazardous area classification for that purpose and be of a type approved by the PESO. The extent of hazardous area for dispenser at ALDS shall be as below, namely: -

- (i) Entire space within the dispenser enclosure cabinet and 46 cm horizontally from the exterior of enclosure cabinet and up to an elevation of 122 cm above dispenser base and the entire pit or open space beneath the dispenser shall be Zone 1;

- (ii) 46 cm vertically above surrounding ground level and horizontally beyond 46 cm up to 6 m on all sides of the dispenser enclosure cabinet shall be Zone 2;
- (iii) The area up to 1.0 m around the fill point shall be taken as Zone 1 and area within 1.5 m of LPG vent shall be considered as Zone 1. The area beyond 1.0 m and up to 4.5 m from fill point and beyond 1.5 m and up to 3 m from LPG vent shall be taken as Zone 2; and
- (iv) The electrical power distribution system shall be as per clause 4.0 of Schedule – 1 of these Regulations.

3.12 Fire Fighting Facilities:

- (i) ALDS having only underground or mounded LPG storage vessels, two numbers of 70 kg dry chemical type fire extinguishers shall be provided;
- (ii) ALDS having above ground LPG storage vessels, hydrants with minimum water pressure of 7 kg/cm² shall be provided at convenient positions for all round coverage of storage vessels and handling area, and water sprinklers with spray density of 10 lpm / m² shall be provided. The fire water pump shall be preferably diesel engine driven with capacity to deliver water at the aforesaid rate and pressure. The minimum fire water storage at the premises shall be that needed for fighting fire at least for one hour; and
- (iii) Additionally, two numbers of 9 kg DCP fire extinguishers shall be provided near tank truck unloading area and one number shall be provided near each dispenser and transfer pump location.

4.0 OPERATING PROCEDURES:

4.1 General:

- (i) Adequate training shall be imparted to the operators, service engineers and the persons doing like jobs and records thereof shall be maintained;
- (ii) Operating personnel of ALDS shall possess adequate knowledge and experience of handling LPG to ensure functioning of the station in a safe and efficient manner;
- (iii) During unloading of the product from the tank truck to the bulk storage vessels, the tank truck shall be parked in the space marked for the purpose;
- (iv) During the period of unloading of fuel from tank truck to the storage vessels, operation of dispensing fuel to motor vehicles shall be suspended;
- (v) During the period of unloading of LPG from tank truck to bulk storage vessel and also while evacuating the storage vessel for maintenance, testing and like other operation all dispensing, maintenance operations and like other operation at ALDS including that for MS or HSD shall be suspended;

- (vi) LPG shall be dispensed only into the fuel tank container of a motor vehicle duly approved by the PESO;
- (vii) LPG shall not be filled in the fuel tank of motor vehicle while the engine of the vehicle is running;
- (viii) The operating procedures shall be displayed at relevant locations for activating the ALDS, unloading of tank truck, LPG dispensing and like other operation;
- (ix) Dos and Don'ts shall be prominently displayed in ALDS;
- (x) Safe ingress, fueling and egress of all vehicles shall be ensured;
- (xi) System of periodic inspection and maintenance of ALDS facilities shall be established as an integral part of operations;
- (xii) Action in the event of emergency shall be clearly established and understood by all concerned and displayed prominently;
- (xiii) Important operational activities shall be logged and records of such activities highlighting receipt, inventory, level, pressure, temperature, equipment running and like other operation shall be maintained;
- (xiv) All repairs, maintenance work and like other operation shall be carried out after issuance of work permit by authorized person.
- (xv) LPG unloading operations shall be carried out under the supervision of authorised person of ALDS and TT crew;
- (xvi) Limits of operating parameters including level, pressure and any other condition as set for sound and safe operations shall not be exceeded. In case any abnormal operating conditions are encountered, the causes shall be investigated and corrective actions be taken;
- (xvii) The operating staff shall maintain vigilance for detection and control of any leakage at the dispensing station; and
- (xviii) During the operations, LPG leaks should be monitored with explosimeter.

4.2 Receipt of Bulk LPG at ALDS:

- 4.2.1 All Checks essential for ALDS safety as given against serial No.1.2 in annexure - III shall be carried out for each tank truck before starting unloading at ALDS in the following manner, namely:
 - (i) Bulk LPG at ALDS shall be unloaded preferably in non-peak hours;
 - (ii) Unloading of bulk T/T shall be carried out only at location as approved by PESO;

- (iii) The unloading of LPG shall be done in presence of the authorised person at ALDS and TT Crew;
- (iv) Fire extinguishers (2 nos of 9 Kg DCP type) to be positioned as an immediate aid to extinguish any fire except that of liquid LPG;
- (v) Storage tank pressure, temperature and level shall be recorded. Crew or operating staff at ALDS shall closely monitor unloading activities;
- (vi) Tank truck shall be placed in drive out position;
- (vii) After placement, engine master control switch shall be switched off, if applicable;
- (viii) Minimum two wooden chokes shall be placed under wheels;
- (ix) Chassis and LPG vessels are to be earthed independently for which bare metal cleats shall be provided;
- (x) Liquid and vapour hose shall be connected after examining integrity of joints using proper studs and the bolts shall not to be used;
- (xi) The main control panel and other panels shall be energized to activate automatic over fill protection, emergency shut down systems, remote operated valves and compressed air systems;
- (xii) The readings of the level gauges provided on the tanks at ALDS shall be recorded;
- (xiii) The tank trucks valves shall be crack opened and checked for leaks;
- (xiv) LPG level in the storage tanks shall be monitored at regular intervals so that it does not exceed 85 %; and
- (xv) On completion of unloading operation, following activities shall be carried out in sequence, namely: -
 - (a) Close the valves rigid liquid and vapour lines connected to the tank truck;
 - (b) The hose contents should be forced into the tank truck by controlled nitrogen pressure. Alternatively, use loading arms or hoses with isolation valves at both ends. Only vapours shall be vented through the vent;
 - (c) Isolate the valves at fill point;
 - (d) Remove hose connection and electrical-bonding wires;
 - (e) Cap the vapour or liquid outlet lines of the tank trucks;
 - (f) Remove chokes placed under the wheels; and

- (g) Record the roto gauge, pressure gauge, temperature gauge readings and final readings provided on the fixed gauging systems of the storage tanks at ALDS;

4.3 Storage of Bulk LPG:

Following shall be ensured for storage of LPG, namely: -

- (i) Filling shall not exceed 85 % of the capacity;
- (ii) The visible portion of vessels shall be inspected daily for any LPG leakage and corrective action if required shall be taken;
- (iii) All gauges like high-level alarm, level indicating devices, temperature and pressure gauges shall be kept in operating conditions at all times and shall be checked daily;
- (iv) Product gauging shall be done before commencement of dispensing operations and also at the time of closing the operations of the ALDS every time; and
- (v) Functioning of remote operated valves shall be checked prior to receiving of product into the storage tanks.

4.3 Dispenser Operation:

- (i) Ensure that the area is safe for refueling;
- (ii) Guide the vehicle to the position at the designated area of the ALDS facing the direction of exit;
- (iii) Do not leave the vehicle unattended during refueling operation;
- (iv) Ensure that sources of ignition, such as pilot lights, electrical ignition devices, electrical appliances or gadgets, and engines located on the vehicle being refueled are turned off before dispensing of LPG to a vehicle;
- (v) Check for stamping of Road Transport Authority in the registration certificate of vehicle prior to refueling;
- (vi) The operator at ALDS shall satisfy himself before commencement of filling in the vehicle in respect of following, namely: -
 - (a) The vehicle is fitted with only approved Conversion Kit and Auto LPG Tank with standard fittings as per AIS 026 or equivalent;
 - (b) A “COMPLIANCE PLATE” is installed near the filling connection which is clearly visible, displaying following information, namely: -
 - (A) Auto LPG Tank identification number;
 - (B) Date of installation;

- (C) Water capacity (Litres) of total installation;
 - (D) Date of last retest;
 - (E) Vehicle Registration or Identification No.;
 - (F) LPG installation complies with the safety requirements of AIS 026; and
 - (G) Installed by (indicate the designation);
- (c) That a green coloured label of size 80 mm x 80 mm with the text “LPG” is affixed either close to the vehicle number plate or on left side of the wind screens;
 - (d) Check for the ‘Automatic Fill Limiter (AFL)’, which shuts off fuel supply to tank at 80 % of tank capacity, on the fill point of the Auto LPG Tank.
 - (e) LPG filling shall not be carried out for vehicles having Auto LPG Tank due for retesting as per Gas Cylinder Rules, 1981. Ensure that the emergency shut-off valve and the manual isolation valves are open on both delivering and return lines.
- (vii) Set the dispenser meter at the quantity or value to be filled;
 - (viii) Position the fill nozzle on the vehicle container and couple securely;
 - (ix) Check that the vehicle fill connection is in sound condition in terms of tightness and leakage;
 - (x) Energize the system through push button and allow flow of LPG into the auto LPG Tank;
 - (xi) When using a filler nozzle with a nozzle bleed valve, open the valve to empty the nozzle before disconnection;
 - (xii) Return the nozzle to correct position after the filling is over; and
 - (xiii) At the end of the day’s work, ensure that valves are closed, hoses are properly stowed and electrical equipment is switched off.

Note: - Commissioning and de commissioning procedure for the ALDS is given in Annexure - IV.

5.0 INSPECTION AND MAINTENANCE:

- (i) A well-designed system of periodic inspection of all facilities of ALDS shall be formulated to maintain it in safe operable condition all the time. Safety audit of the ALDS shall be undertaken and certificate of fitness declaring integrity with respect to equipment, facilities, operations and safety procedures shall be accordingly issued. Check list for inspection is specified in Annexure -III;
- (ii) All recommendations of the safety audit or inspections shall be complied in a time bound manner and records maintained thereof;

- (iii) Disassembly or removal of the facilities and components of equipment whilst any part of the system is under pressure is hazardous and shall not be undertaken unless the system is depressurised, gas freed and certified;
- (iv) The system of permit to work shall be established for non-routine works in line with the work permit issued by authorised person and such works shall be undertaken with full knowledge and approval by authorised person for such purpose. The work permit shall be in line with Annexure-vi (A) and vi (B) of Schedule – 1;
- (v) Equipment appurtenances, protection devices associated with the dispensing unit as incorporated in the design and approved by PESO shall be tested, maintained, repaired and replaced as recommended by the manufacturer;
- (vi) Checklist shall be in conformity with the design intention, operating and maintenance procedures, preventive measure and protection systems and safety practices;
- (vii) Preventive maintenance schedules shall be drawn for all equipment in accordance with manufacturer's recommendations and established mandatory or recommendatory standards. Records of all preventive maintenance undertaken shall be maintained and updated from time-to-time; and
- (viii) Calibration of dispenser shall be carried out in line with statutory applicable.

6.0 TESTING OF RELIEF AND PROTECTION SYSTEM:

- (i) All periodic tests shall be carried out by competent or authorised persons in this behalf, as applicable and records shall be maintained;
- (ii) For in house testing of safety relief valve, only properly built, testing facilities shall be used;
- (iii) After the calibration or re-calibration of the safety relief valve and excess flow check valve, it shall be certified by competent person; and
- (iv) A schedule for testing of Relief Valves and Protection System of various equipment shall be developed. The checks shall be done as specified by manufacturer. The frequency of testing shall be either as given below or as recommendation by manufacturer whichever is of shorter period, namely: -

Equipment or Facility	Frequency	Agency
Safety Relief valve	Once in a year	Competent person
Thermal or Hydrostatic relief valve	Once in a year	Competent person
Excess Flow Check Valve	Once in a year	Competent person
High Level Alarm of storage vessel	Once in 6 months	Competent or authorised person in this behalf.
Remote Operated Valves	Once in 6 months	Competent or authorised person in this behalf.

LPG Pump or Compressor Trips	Once in 6 months	Competent or authorised person in this behalf.
Compressor Trips	Once in a quarter	Competent or authorised person in this behalf.
Emergency Push Button Trips	Once in a month	Competent or authorised person in this behalf.
Breakaway Coupling	Once in 6 months	Authorised person in this behalf.
Cathodic Protection System	Once in a year	Authorised person in this behalf.
Piping Network	Once in five years along with tank testing	Authorised person in this behalf.
LPG Unloading Hoses	Once in 4 months	Authorised person in this behalf.
Fire Extinguishers	Once in 6 months	Authorised person in this behalf.
Dispensing hoses	Once in 6 months	Authorised person in this behalf.

7.0 SAFETY INSPECTIONS and AUDIT:

The safety inspections or audit of ALDS shall be carried out as given below:

TYPE	FREQUENCY	AGENCY
General Inspection	Daily	Operating personnel
	Twice in a quarter	Authorised personnel of marketing company
Safety Audit	Once in a year	Authorised Person in this behalf
Electrical Audit	Once in three years	Licensed Electrical agency

Note: - The comprehensive checklist shall be developed in line with the similar checklists provided in Schedule – 1.

8.0 EMERGENCY PLAN AND PROCEDURE:

- (i) A comprehensive ERDMP shall be developed in accordance to the Petroleum and Natural Gas Regulatory Board (Codes of Practices for Emergency Response and Disaster Management Plan (ERDMP)) Regulations, 2010. The copies of the ERDMP shall be available to all personnel in the Auto LPG Dispensing Station;
- (ii) The entity having control over the ALDS shall draw an operational emergency plan keeping in view the following, namely: -

- (a) Loss of, or interruption to, the gas supplies due to leaks or failure of pipeline;
- (b) Major failure of LPG fittings;
- (c) Accidents or other emergencies, which can affect the ALDS;
- (d) Civil emergencies;
- (e) Any other risk arising from the existence or operation of the ALDS;

and such emergency plan shall be disseminated amongst all personnel involved insuring that they understand their roles and responsibilities in the event of an emergency.

- (iii) Each ALDS shall be provided with at least 3 shut down devices located in convenient locations near storage vessels, dispenser and office/ sales room;
- (iv) The in-charge of the ALDS shall maintain close liaison with Fire Service, Police, District Authorities and LPG marketing company;
- (v) Important telephone numbers for emergency use shall be displayed prominently in the ALDS and
- (vi) Means of communication shall be always at the disposal of the In-charge of the ALDS.

9.0 COMPETENCE ASSURANCE AND ASSESSMENT:

- (i) The objective is to provide good understanding of all the facets of dispensing activities including operations, procedures, maintenance and hazards of LPG and the risks associated with its handling. Training shall ensure that the jobs are performed in accordance with the laid down procedures and practices;
- (ii) Every entity shall develop, implement, and maintain a written training plan to instruct all ALDS with respect to the following, namely: -
 - (a) Carrying out the emergency procedures that relate to their duties at the ALDS as set out in the procedure manual and providing first aid;
 - (b) Permanent maintenance, operating, and supervisory personnel with respect to the following, namely: -
 - (i) The basic operations carried out at the ALDS;
 - (ii) The characteristics and potential hazards of ALDS and other hazardous fluids involved in operating and maintaining the ALDS, including the serious danger from frostbite that can result upon contact with POL products including LPG;
 - (iii) The methods of carrying out their duties of maintaining and operating the ALDS as set out in the manual of operating, maintenance and transfer procedures;

- (iv) Fire prevention, including familiarization with the fire control plan of the ALDS; fire fighting; the potential causes of fire or accident in ALDS; the types, sizes, and likely consequences of a fire/ accident at ALDS;
 - (v) Recognizing situations when it is necessary for the person to obtain assistance in order to maintain the security of the Petroleum Retail Outlet;
- (iii) Training shall be imparted by competent personnel to the staff attached with the LPG dispensing station at the time of induction, which is to be followed up by periodic refresher courses. The training programme shall inter alia cover following aspects, namely: -
- (a) Hazardous characteristics of LPG;
 - (b) Familiarisation with operational procedures and practices;
 - (c) Commissioning of new facilities and equipment;
 - (d) Hands on experience on operation of equipment;
 - (e) Routine checks and maintenance activities of the facilities;
- (ii) Knowledge of emergency and manual shut down systems shall inter alia cover following aspects, namely: -
- (a) Immediate and effective isolation of any LPG leak;
 - (b) Accounting of product;
 - (c) Safety regulations and accident prevention;
 - (d) Fire fighting facilities, its upkeep and operation;
 - (e) Evacuation and safe egress of the vehicles in an emergency;
 - (f) Housekeeping;
 - (g) Safety in transportation of LPG;
 - (h) First aid; and
 - (i) Emergency plan. or drills; and
- (iii) Proper records for the training and refresher courses shall be maintained at the installation.

10.0 CUSTOMER SAFETY AND AWARENESS:

10.1 Display of important information:

At ALDS, the particulars of licence, emergency telephone nos. of local fire service, police, LPG marketing company and emergency instructions shall be conspicuously displayed in the following manner, namely: -

- (i) Caution boards shall be displayed near the dispenser for customer awareness as below, namely: -
 - (a) Stop the engine before refueling;
 - (b) No smoking;
 - (c) No flames or pilot lights or use of electrical gadgets;
 - (d) Avoid contact with liquid LPG;
 - (e) Do not fill LPG beyond 80 % capacity; and
 - (f) Keep distance from vehicle being fueled.
- (ii) A display board shall be prominently placed at ALDS for the benefit of the Customer highlighting behavioral characteristics of LPG in bilingual i.e. Hindi or English and local language as below, namely: -
 - (a) Auto LPG is stored and delivered as a liquid under pressure;
 - (b) While changing from liquid to gas, LPG expands approximately 260 times its original volume;
 - (c) Leakage of liquid LPG is more dangerous than gaseous LPG and it has distinct odour; and
 - (d) LPG vapour is approximately 1.5 times heavier than air, LPG vapour tends to settle down.

10.2 DOs & DON'Ts:

DON'Ts:

- (i) Do not start the engine or drive away the vehicle till the filling nozzle has been disconnected from the filler cap of the vehicle;

- (ii) Do not refuel the vehicle during the period LPG is being decanted the storage vessel;
- (iii) Do not handle LPG without protective hand gloves and safety glasses; and
- (iv) Do not fill in the Auto LPG Tank which is overdue for pressure retesting.

Dos:

- (i) Switch off the mobile phone at the ALDS;
- (ii) Switch off the engine before commencement of refueling of Auto LPG;
- (iii) Check vehicle tank spout valve and its rubber seal;
- (iv) Squeeze trigger fully and hold;
- (v) Ensure a 9 kg DCP Fire Extinguisher is available near the LPG Dispenser;
- (vi) Connect Nozzle to avoid cross threading; and
- (vii) In case of any leakage or fire observed, press the “EMERGENCY STOP” button on the LPG Dispenser.

11.0 List of Standards or Guidelines referred to in Schedule 2 shall be as given in Annexure V.

VANDANA SHARMA, Secy.

[ADVT.-III/4/Exty./365/18]

ANNEXURE - II

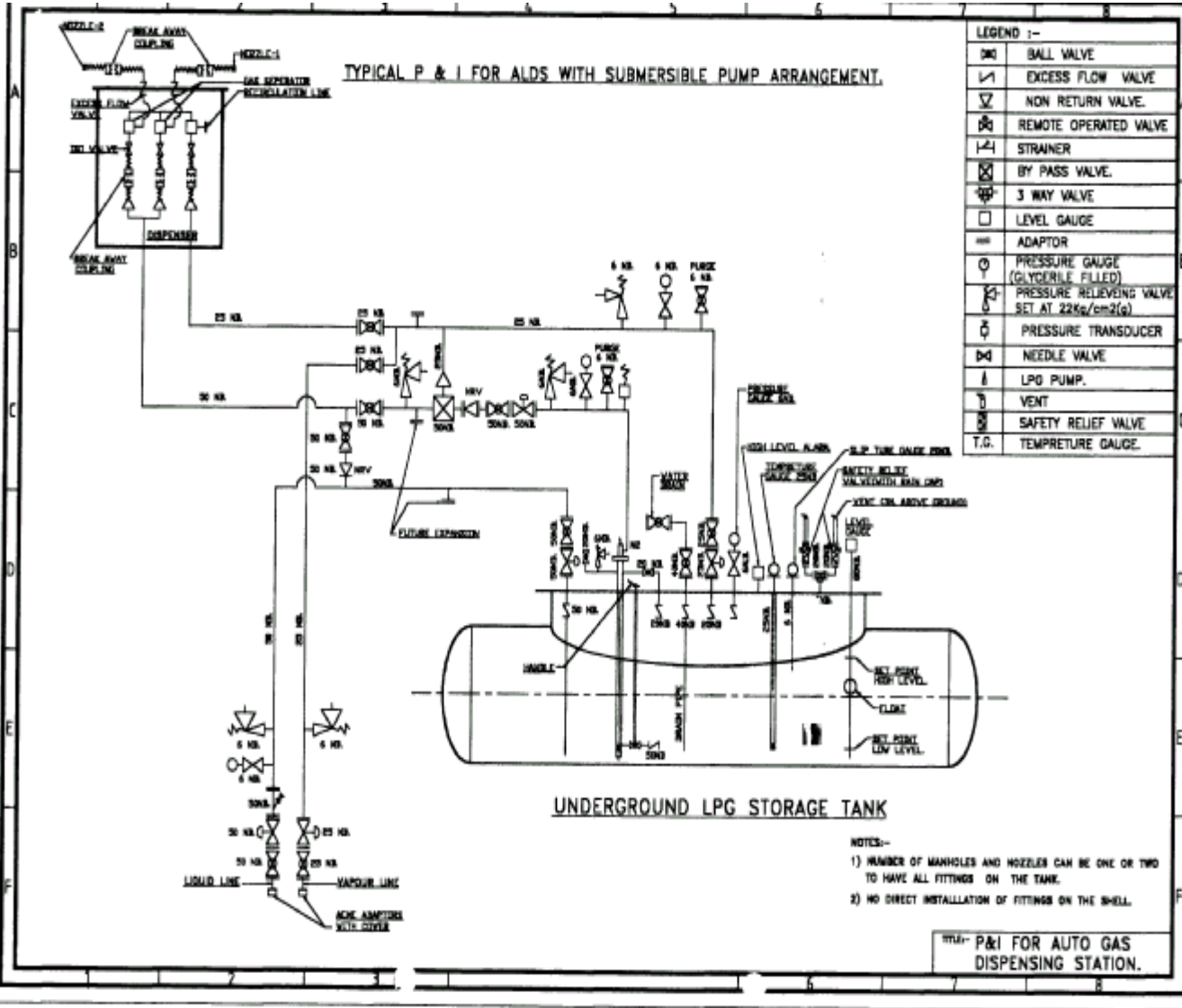

Annexure - III

INSPECTION OF THE AUTO LPG DISPENSING STATION

S. No	ITEMS	OBSERVATIONS (State details)	Remarks/ Recommendations
1.0	CHECKLIST:		
1.1	Bulk Storage Area:		
	Condition of earthing of vessels.		
	Functioning of level instruments.		
	Safety valves regularly tested and records maintained.		
	Functioning of level gauge and high-level alarm.		
	Any sign of leakage or corrosion.		
	Positioning of fire extinguishers.		
	Fence around storage vessel is 2 m high		
	Conditions, functioning and coverage of sprinkler or hydrant system.		
	No simultaneous unloading of LPG and other fuel		
	Illumination level adequate.		
	Condition of cathodic protection system, current, potential		
	Storage area is properly paved		
	No vegetation in the area		

	No unauthorised structure up to the property line		
	Housekeeping.		
1.2	Tank lorry unloading:		
	Approved spark arrestor fitted with the tank lorries.		
	Proper earthing connections and earth pit resistance.		
	Any visible sign of LPG leakage.		
	All flanges completely bolted		
	Only metallic gaskets in use		
	Bolts and nuts protected against corrosion		
	Electrical resistance within limits		
	PESO license for the vehicle.		
	Hose test certificate available		
	2 nos. of fire extinguishers in the vehicle.		
	Tool kit available		
	First aid box available		
	Flange connections having bonding.		
	Safety instruction booklet or TREM Card available.		
	Wheel choke used while unloading.		
	Portable extinguisher positioned and functional		
	Tank lorry in drive out position		
	Illumination level adequate.		
	Housekeeping in order.		

1.3	Dispensing pump:		
	Leakage from pump seals.		
	Lubrication effective.		
	Flameproof fittings and junction box.		
	Earthing connections proper.		
	Alarms and trips functioning.		
	ROV's can be actuated from remote location		
	Telephone in sales room		
	Safety guards in position.		
	Abnormal vibration or excessive noise.		
	Portable fire extinguishers in position.		
	Signs of visible leakage.		
	Vent and drains with double block valves and without leakage.		
	Housekeeping in order.		
	Ignition source in the surrounding.		
1.4	Dispensing Unit:		
	Effective arrangement to protect against collision damage.		
	EFCV and breakaway coupling provided and are functional/ test report available.		
	Filling hose is tested, test report available and due date is marked.		
	Fueling nozzle is of self-sealing type.		
	Leakage from nozzle is within 5 ml and is certified or tested		

	Filling operation cannot be started unless the system is properly earth.		
	Filling nozzle is in lockable position		
	Filling nozzle capped when not in use		
	No fugitive emission while disconnecting the nozzle.		
	Dispenser is equipped with a device for emergency shutdown of entire dispensing unit.		
	All valves, meeting equipment, vapour eliminator and other equipment installed on the dispenser is duly recognised by a CCOE or testing laboratory.		
	Cut off valve of the dispenser is in closed position when the dispenser is not activated.		
	Pull away device (Break away coupling) provided in transfer hose and is functional.		
	Means provided to prevent LP gas from being discharged unless the nozzle is connected to the vehicle.		
	The fueling nozzle is provided with a swivel inlet connection (360 deg.)		
	Electrical components suitable for class I, group D, division – I applications.		
1.5	Electrical System:		
	Transformer in conformity with area classification.		
	Area classification duly approved by CCOE available.		
	Alarm and trip circuit functioning.		
	No temporary electrical connection.		
	Condition of cable duct and wiring good.		

	Rubber mats with ISI mark.		
	Fuse are of proper type and rating.		
	Fire extinguishers are in proper working condition.		
	Motors provided with double independent earthing connection.		
	Flame proof ness of terminal box, fitting and junction boxes maintained and certificates available.		
	Earthing pit condition good.		
	Push buttons earthed properly and flameproof conditions not tampered.		
	Ground resistance at motor or push button measured and found satisfactory.		
	Water accumulation in lighting fixture distribution box.		
	Lighting fixture flameproof and as per area classification.		
	LPG pipelines with jumper for electrical continuity.		
	Condition of grounding electrode.		
	Area classification duly approved by CCOE available.		
	Records of electrical testing checks maintained up-to-date.		

Annexure - IV

Commissioning & Decommissioning Procedures

1.0 General:

- (i) The commissioning or de-commissioning operations shall be carried out by well trained and experienced personnel;
- (ii) The commissioning or de-commissioning operations shall be preferably during daytime. Such operations shall be done when traffic in the vicinity is minimum;
- (iii) Caution boards shall be displayed while venting is in progress
- (iv) The surrounding area shall be cordoned off and the gas level shall be monitored closely using explosimeter and
- (v) Fire fighting facilities shall be kept ready.

2.0 Commissioning, purging and charging of new vessels:

Pre-commissioning inspection and certification by the competent authority shall be obtained prior to initiating the activities specified in paragraph 3.0 to 6.0

3.0 Water or Nitrogen filling:

- (i) All gaskets shall be changed after hydrotest;
- (ii) The LPG system shall be first filled with clean water or Nitrogen. This will assist displacement of air followed by replacement of water or Nitrogen by introducing vapour LPG. Liquid LPG should not be introduced under any circumstances for purging the vessels;
- (iii) At the time of filling water or Nitrogen, air shall be released from vent points;
- (iv) At this stage the system shall be checked thoroughly for leak-proof ness;
- (v) The complete leak testing during commissioning at 10 % above the working pressure but not exceeding design pressure of the vessel, shall be a proof test over and above the hydro test undertaken for various equipment and facilities at earlier stage. This will ensure leak proof ness of the system as a whole before gas charging;
- (vi) Particular attention shall be given with respect to the fittings, connections and joints of the storage vessel. In case of any leakage is found the vessel shall be depressurised and water or Nitrogen drained or removed for taking corrective action; and

(vii) Gasket shall be checked and replaced in case any flange joint is found leaking during leak testing.

4.0 Gas charging:

- (i) Liquid or vapour LPG shall not be directly used for displacement of air in storage vessels since the system is likely to contain a flammable mixture for a period of time, which shall be ultimately vented to the atmosphere;
- (ii) Gas shall be charged only after ensuring elimination or absence of oxygen;
- (iii) Vapour from LPG tank lorry shall be used for gas charging, taking due precaution that temperature of the contents does not drop substantially;
- (iv) While charging gas, water or nitrogen shall be drained simultaneously maintaining a positive pressure of around 1-2 kg/sq.cm. in the vessel;
- (v) Pressure in the storage system shall be monitored and creation of vacuum condition to be prevented;
- (vi) At the time of draining of water, it shall be ensured that no pockets of water remain in the system;
- (vii) Where water draining is resorted to, by opening of end flanges of headers or lines, such flanges shall be blinded at the end of draining operation;
- (viii) In case of displacement of Nitrogen with LPG vapour, constant readings of LPG air mixture should be taken with explosimeter to ascertain the displacement of Nitrogen with LPG vapours;
- (ix) Functioning of the level gauges, high level alarm and their correctness shall be checked at the time of water filling and gas charging; and
- (x) Provision shall be made for proper drainage of water from vessels, pipe lines and equipment. In case of Nitrogen displacement, controlled venting should be done from pipelines and equipment to ascertain Nitrogen displacement with LPG. Explosimeter reading shall also be taken to check the concentration levels.

5.0 Liquid charging:

- (i) Liquid LPG shall be introduced at a controlled rate after displacement of entire water or Nitrogen with vapour LPG;
- (ii) The commissioning operations shall be controlled and supervised by authorised personnel in this behalf; and.
- (iii) Fire fighting system shall be kept in readiness.

6.0 Commissioning of Dispensing unit:

- (i) For commissioning of dispenser unit, liquid LPG shall not be charged and displacement of air shall be carried out by introducing vapour LPG from the storage vessel and venting under controlled conditions with due safety precautions;
- (ii) Water charging during pressure testing shall be limited up to the inlet of the dispenser so that internals appurtenances, instruments, metering element and all other accessories are not affected, but, there are no restrictions if Nitrogen is used for purging; and
- (iii) Manufacturer's recommendations shall be followed while commissioning the dispensing unit.

7.0 Decommissioning and Gas Freeing of Storage Tanks:

- (i) Water or Nitrogen shall be used for gas freeing adopting procedures similar to water or Nitrogen filling and gas charging during commissioning;
- (ii) For decommissioning of storage vessels, liquid shall be first exhausted using pumps or compressors followed by displacement of gas by water or Nitrogen;
- (iii) The liquid LPG can be transferred to the adjacent tank or a road tanker;
- (iv) In case compressor is available, pressure in the system shall be reduced by recovering vapour from the storage vessel and transferring to another vessel if the layout of the system so permits;
- (v) While introducing water or Nitrogen, residual vapour in the storage vessel shall be released at controlled rate by venting through cold flare; and
- (vi) Check that the vessel is gas free with explosimeter.

Annexure – V

REFERENCES

- (i) Regulation for LPG Service and Road Tank Trucks in the Netherland, 1987.
- (ii) Code of Practice 11: Recommendations for the safe handling of LPG used as an internal combustion engine fuel for motor vehicles (LPG ITA).
- (iii) AS/NZS 1596:1997: Storage of Handling of LP Gas.
- (iv) AIS 026 D1 : The use of LPG Fuel in Internal Combustion Engine to Power 4-Wheeled Vehicles.
- (v) IS:2825 : Code for Unfired Pressure Vessels.
- (vi) IS:5571 : Guide for Selection of Electrical Equipment for Hazardous Area.
- (vii) IS:5572 : Classification of Hazardous Areas (other than mines) having Flammable Gases and Vapours for Electrical Installations.
- (viii) IS:14861 : BIS Specification of LPG for automotive purposes.
- (ix) IS:14899 : Liquefied Petroleum Gas containers for automotive use – Specification.
- (x) The Static and Mobile Pressure Vessels (Unfired) Rules-1981.
- (xi) LPG (Regulation of use in Motor Vehicles) Order, 2001.
- (xii) Gas Cylinder Rules, 2004.
- (xiii) API Standard 25 – Design and Construction of LP Gas Installations;
- (xiv) ASME Boiler and Pressure Vessel Code Sect. VIII Division 1 American Society of Mech. Engrs., New York.
- (xv) NFPA 58 : Storage and Handling of Liquefied Petroleum Gases.
- (xvi) NEPA 59 : LP Gases at Utility Gas Plants.
- (xvii) ASME B - 31.3 : Chemical Plant and Petroleum Refinery Piping.
- (xviii) PD-5500 : Specification for unfired fusion welded pressure vessels.

SCHEDULE – 3

[see regulation 6(3)]

STORAGE, HANDLING AND DISPENSING AT CNG DISPENSING STATIONS

1.0 SCOPE:

The technical standard and specifications including safety standards under this Schedule lay down the minimum requirements in design, operation, inspection, maintenance, training, consumer safety at Retail Outlets dispensing CNG and do not cover the certification or fitness requirements of vehicles.

2.0 DEFINITIONS:

In these regulations, unless the context otherwise requires,

- (a) “Bulk Storage” means a facility for storing CNG in stationary and mobile storages exceeding the water capacity of 1000 Lt. and these pressure vessels shall conform to the “Static & Mobile Pressure Vessels (Unfired) Rules, 1981;
- (b) “Cascade (Gas Storage Unit -Bundles of cylinders, Multi-Element Gas Cylinders-MEGCs, Tube Modules or Skids)” means a group of gas cylinders interconnected by high-pressure tubing to form a single gas storage unit herein after in this Schedule referred to as cascade and such cascade may also used for transportation of CNG in the structural frame work having facility for lifting and placement;
- (c) “Cascade Storage Unit Isolation Valve” means a quick action valve for stopping gas flow from a gas storage unit;
- (d) “Compressed Natural Gas (CNG)” means mixtures of hydrocarbon gases and vapours, consisting mainly of Methane in gaseous form which has been compressed for use as automotive fuel conforming to IS: 15958 / IS: 15320:2012;
- (e) “CNG Mother Station” means CNG facility connected to natural gas pipeline and having a compressor meant primarily to fill mobile cascades and such facilities, in addition to act as ‘mother’ station can also fill stationary cascades for CNG dispensing into vehicles;
- (f) “CNG On line Station” means CNG facility connected with natural gas pipeline and having a compressor primarily to fill stationary cascades for dispensing CNG to vehicles and in case the ‘on line’ station has enough space to accommodate mobile cascades filling, it can be used to act as mother compressor station;
- (g) “CNG daughter station” means CNG facility not connected to natural gas pipeline and dispensing CNG to the vehicles through mobile cascades;
- (h) “CNG daughter booster Station” means CNG facility not connected to natural gas pipeline and dispensing CNG to the vehicles through CNG booster compressor and mobile cascade;

- (i) “Cylinder Appurtenances” means devices connected to cylinder for safety, control or operating purposes;
- (j) “Cylinder” means any closed container having capacity exceeding 500 ml but not exceeding 1000 litres, constructed as per IS 7285-1, IS 7285-2, ISO 11119-1, ISO 11119-2, ISO 11119-3, ISO 11120, EN 12245, EN 12247 or other international standards having approval from statutory authority under Gas Cylinders Rules,2004 and such cylinders. may be of varied capacities to suit vehicles and storage systems and the water capacity of cylinders used for storage of CNG, may exceed 1000 litres up to 2500 litres provided the diameter of such cylinder does not exceed 60 cm;
- (k) “Emergency Shut Off Valve” means a quick action shut off valve, which operates from full open to full closed condition in less than one complete turn;
- (l) “Fire Resistance Rating (FRR)” means the minimum period of time for which all sides of an element of structure, any of which is subjected to a standard fire, continues to perform its structural function and does not permit the spread of fire and where a period of time is used in conjunction with the abbreviation FRR it is required that the element of structure referred to shall have a fire resistance rating of not less than the period stated in accordance with IS 1642:1989;
- (m) “Manifold” means the assembly of piping or tubing and fittings used for interconnecting all cylinders or vessels to a common pipeline;
- (n) “Maximum Working Pressure” means the pressure for which the equipment was fabricated or manufactured or if conditions have changed, the maximum permitted pressure at specified design temperatures;
- (o) “Point of Transfer” means the point where the filling or fueling connection is made, to vessels or vehicle;
- (p) “Pressure Relief Device” means device designed to prevent rupture of vessel or container by releasing excessive pressure build-up;
- (q) “Set Pressure” means the valve opening pressure in a relief valve which shall not exceed the marked service pressure;
- (r) “Transportation unit” means a cascade or bulk storage mounted and installed on a light or heavy commercial vehicle, trailer, or semi-trailer for movement of CNG on road and governed by statutory regulations;
- (s) “Trailer” means a trailer or semi-trailer motor vehicle designed specifically for the transportation of cylinder bundles with its associated structural framework;
- (t) “Vehicle Refueling Probe” means a CNG refueling device fitted at the end of the refueling hose at the dispenser units; and

- (u) “Vehicle Refueling Shut Off Valve” means a quick action valve for stopping gas flow and having the facility for venting residual high-pressure gas in the refueling line after completion of the vehicle refueling operation;

3.0 NATURAL GAS QUALITY FOR CNG FACILITIES:

3.1 Quality of Compressed Natural Gas (CNG) for automotive purposes is governed by IS:15958.

3.2 ODOURISATION:

3.2.1 Natural gas introduced into any system covered by the standard should have a distinctive odour strong enough to detect its presence down to a concentration (of CNG) in air not exceeding 20% of the lower limit of flammability and to achieve such standard, the injection of odorizing agent shall be done in a quantity to ensure perception of CNG leakage by smell as per IS:15319.

3.2.2 Suitable type of filters shall be used for limiting liquid particulate as mentioned in paragraph 3.2.1.

3.2.3 In case the natural gas is not odourised, the odourisation and filtration system shall be located in a separate working area from the compressor or CNG storage unit but within the same fencing and these should be a clear safety distance of 1.5 M around the odourisation and filtration system to facilitate easy maintenance and personnel movement.

3.2.4 The odourisation pumping as well as filtration system shall have 100% stand-by capacity.

4.0 FACILITY PLANNING:

4.1 The CNG refueling system shall comprise of a gas compression apparatus, static or mobile cascade or pressure vessel and a gas dispenser incorporating a measuring device and the CNG station can also have an air compressor and an air dryer system for actuation of valves and the system shall be `ON-LINE' mother refueling or daughter dispensing system attached to a mobile cascade.

Note: - The systems and components of CNG facility(ies) shall be certified for CNG use and marked accordingly by applicable statutory authority or the agency authorized by such authority.

4.2 LAYOUT AND INTERDISTANCES:

4.2.1 Inter-distances between various equipment, storage cylinders or cascade and like other device shall be as per Tables occurring in the Schedule.

4.2.2 Safety distances not indicated in paragraph 4.2.1 should be as approved by Petroleum and Explosives Safety Organisation on case to case basis after due consideration of all influencing factors.

- 4.2.3 Inside a MS or HSD Service Station, the CNG storage and dispensing facilities shall be located in an isolated area not interfering in the vehicular movement on the drive way and not coming within the hazardous areas of petroleum facilities as prescribed in the Fourth schedule of the Petroleum Rules, 2002 And the CNG facilities shall not be located beneath bare electric power lines or where exposed by their failure.
- 4.2.4 The compressor fencing may be limited to avoid obstruction in the driveway if the required clear space is available thereafter within the service station premises and the dispensing unit may also be located farther from the fence enclosure on a separate pedestal observing the minimum safety clearance mentioned in Table II in this Schedule.
- 4.2.5 CNG Compressors or Storage units installations shall be permitted to use alternate equipment locations (e.g. when installed on the top of the RCC canopy) with validation by a qualified engineer with proven expertise in mechanical systems, structural system, electrical systems, gaseous storage systems, fire protection, and gas detection and if compressor is installed on the top of the canopy, installation of cascades above such compressor shall not be permitted and the validation shall at a minimum include the following, namely:-
- (i) Process safety analysis and hazard and operability studies (HAZOPS);
 - (ii) Mitigating fire protection measures such as suppression system as per NFPA-17. Further, if compressor is mounted inside soundproof canopy or enclosure, automatic CO2 flooding system as per NFPA-12 shall be provided;
 - (iii) Fire and gas detection systems designed to interface with an emergency shutdown device (ESD);
 - (iv) The structure supporting such installations shall meet 4 Hr Fire rating in line with IS 1642:1989-Code of practice for fire safety of buildings;
 - (v) IS 875- Part 1 to 5 (1987): Code of Practice for Design Loads (Other than Earthquake) for Buildings and Structures including for movable and immovable loads, vibrations at partial or full loading conditions of the CNG compressor;
 - (vi) The structure, Foundation shall be designed for the seismic zone as per IS 1893 (Part 1) 2002 for Seismic loads;
 - (vii) Alternate Emergency escape routes shall be provided for operating crew in case the equipment is installed at top of the canopy or elevated platform;
 - (viii) Protective hand railings shall be provided on such elevated roof top's or elevated platforms to prevent accidental fall of operating crew;

- (ix) Weather protection from sun and rain (ventilated canopy) shall be provided for cascades;
- (x) Emergency shut down (ESD) system shall be provided and this device, when activated, shall shut off the power supply to the compressor and gas supply to the dispenser immediately;
- (xi) An emergency manual shutdown device shall be provided within 3.0 m of the dispensing area and also at a suitable remote manned location;
- (xii) Control circuits shall be arranged so that, when an emergency shutdown device is activated or electric power is cut off, systems which shut down remain off until manually activated or reset after a safe condition is restored; and
- (xiii) The main stairs for accessing such elevated platform shall be minimum 1.2 m wide.

4.2.6 Provisions related to Convenience store or ATM or office cabin shall be regulated in the following manner, namely: -

- (a) The items to be sold from a Convenience Store (C-Store) in a retail outlet shall be decided keeping in view hazards associated with the items being stocked and sold and the open flame appliances shall not be used in the retail outlet;
- (b) Provision for car parking shall be made in retail outlet with C- Store @ one slot distinctly marked for each 25 sq metre of C-Store area;
- (c) Separate pathways outside dispensing area shall be provided for movement of customers for C-Store;
- (d) The CNG dispensers shall maintain a minimum distance of 4 mts from any above ground structure or property boundary; and
- (e) Any building or room intended to serve as a control point for a retail outlet shall preferably be so located that an attendant in the sales room can see the forecourt and dispensing area clearly.

TABLE - I
INTER DISTANCES
FROM BUILDINGS AND OUTER BOUNDARIES TO GAS STORAGE UNITS

Total capacity of gas storage units (In litres) (1)	Minimum distance from Buildings and boundaries (In Meters) (2)
Up to 4500	2.5
4500 to 10000	4.0
10000 to 100000	10.0

Note:

1. If on the side towards the boundary of the installation, the clearance as specified in the Table is not available, the same may be reduced to 2 meters provided a 4 H-FRR (As per IS 1642 (1989)) RCC wall of adequate height and length covering the cylinder cascades is constructed at the boundary and adequate clear space is available on the other side of the wall;

2. If Multiple cascades are located maintaining inter-distance of minimum 1 m, then, the required safety distances shall be considered as applicable in case of the water capacity of the higher capacity individual cascade,

TABLE - II
INTER DISTANCES BETWEEN VARIOUS FACILITIES OF NATURAL GAS
HANDLING AT INSTALLATION

	Distance from - In metres	1	2	3	4	5	6	7
		CNG Compressor	CNG Dispensing Unit	Storage Cascade	Outer boundary wall or Chain link fencing	MS or HSD dispenser	Vent of MS or HSD u/g Storage tanks	Fillin g point of MS or HSD
1	CNG Compressor	-	3	2	3	6	6	T1 (Min-3)

2	CNG Dispensing Unit	3	-	2	4	6	4	-do-
3	Storage Cascade	2	2	-	T1	T1 (min-6)	T1 (Min-4)	-do-
4	Outer boundary wall or Chain link fencing	3	4	T1	-	6	4	-do-
5	MS or HSD dispenser	6	6	T1 (Min-6)	6	-	6	-do-
6	Vent of MS or HSD u/g Storage tanks	6	4	T1 (Min-4)	4	6	-	6
7	Filling point of MS or HSD	T1 (Min-3)	T1 (Min-3)	T1 (Min-3)	T1 (Min-3)	T1 (Min-3)	6	*

NOTES:

- (i) T-I denotes Table-I;
- (ii) Distances shown as “-” shall be any distance necessary for operational convenience;
- (iii) A suitable curbing platform shall be provided at the base of the dispensing unit to prevent vehicles from coming too near the unit;
- (iv) A CNG cascade having cylinders of total water capacity not exceeding 4500 liters can be mounted on top of the compressor super structure. The assembly shall observe 3-meter clearance around and also from the dispensing unit and such distance can be reduced to 2 meter as per Note- I of Table – I; and
- (v) * As per Schedule – 1 of these regulations

5.0 CNG STORAGE SYSTEM (Static):

- 5.1 The cascade having horizontal cylinders and sited parallel to other cascade or cylinder fittings should be arranged so that they do not face cylinder fittings of other cascade.
- 5.2 Cylinder installed horizontally in a cascade shall be separated from another cylinder in the cascade by a distance of minimum 20mm.

- 5.3 Cascade with horizontal cylinders shall have the valves fitted on the same side within the cascade opposite to the refueling point and arranged in a manner that any gas leakage is discharged upwards.
- 5.4 Cascade or bulk units shall be installed on a firm, compacted, well-drained non-combustible foundation and such foundation may be in the form of a plinth with the raised edge at 2 M from the front and sides of the cascade forming a kerb up to which vehicles should be permitted and the cascade shall be securely anchored to prevent floating in case flooding is anticipated.
- 5.5 Gas storage facility shall be protected from the effects of the weather by a roof or canopy designed to facilitate the dispersion of free or escaped gas.
- 5.6 Adequate means shall be provided to prevent the flow or accumulation of flammable or combustible liquids under containers such as by grading, pads or diversion curbs.
- 5.7 The provisions of clauses (iv), (v), (vi), (ix) and (x) of paragraph 6.5 shall also be applicable for static CNG storage system.
- 5.8 Cascade storage on the top of the roof shall be permitted on first floor and there shall not be any further construction or inhabitation above this storage.
- 6.0 CNG STORAGE SYSTEM (Mobile):
- 6.1 Only dedicated trailer, truck or any other vehicle to be used for transportation of CNG storage units and such units should have lugs fitted for lifting and in no case magnetic device to be used for lifting purposes.
- 6.2 The vehicle with the cascade thereon, shall be placed with easy access and egress on a low platform or hard compacted ground, which shall extend to atleast another one meter on all sides and this platform or hard ground shall be under a light roof or canopy as described in paragraph 5.5.
- 6.3 For other inter-distances Tables I, II of this Schedule shall be referred.
- 6.4 The trailers or vehicle carrying CNG should be made immovable by application of brake and wheel choke prior to initiation of filling or dispensing operation.
- 6.5 Whether attached to a trailer or mounted on a vehicle chassis frame the cascade shall be designed to meet the following; namely:-
- (i) The cylinders in a cascade must be structurally supported and held together as a unit and secured in a manner that prevents movement in relation to the structural assembly and movement that would result in the concentration of harmful local stresses and the frame design must ensure stability under normal operating conditions;
 - (ii) The frame must securely retain all the components of the bundle and must protect them from damage during conditions normally incident to transportation and the method of

cylinder restraint must prevent any vertical or horizontal movement or rotation of the cylinder that could cause undue strain on the manifold or cylinder shell and the total assembly must be able to withstand rough handling, including being dropped or overturned. (Refer CGA TB 25 Design Considerations for Tube Trailers or Tube Modules);

- (iii) The frame must include features designed for the handling and transportation of the bundle;
- (iv) The frame structural members must be designed for a vertical load of 2 times the maximum gross weight of the bundle and the design stress levels shall not exceed as per IS 800;
- (v) The frame must not contain any protrusions from the exterior frame structure that could cause a hazardous condition;
- (vi) The frame design must prevent collection of water or other debris that would increase the tare weight of bundles filled by weight;
- (vii) The floor of the bundle frame must not buckle during normal operating conditions;
- (viii) Each new Cascade design beyond 4500 litres water capacity must have a design approval certificate and the manufacturer shall obtain approval of a new design along with the copies of all engineering drawings, calculations, and test data necessary to ensure that the design meets the relevant specification from a firm of repute e.g. FM / UL;
- (ix) The cylinders shall be manufactured as per IS 7285-1, IS 7285-2, ISO 11119-1, ISO 11119-2, ISO 11119-3, ISO 11120, EN 12245, EN 12247;
- (x) Individual cascade shall have all cylinders of a particular make, type and capacity and all cylinders in a cascade shall conform to a single design code (mentioned above in para (8.5 ix));
- (xi) Seamless cylinders longer than 2 m (6.5 feet) shall be mounted horizontally for transportation on a motor vehicle or in an ISO framework or other framework of equivalent structural integrity in accordance with CGA TB-25;
- (xii) For the dimensions of ISO framework for transportation, the ISO 6346 shall be referred;
- (xiii) Arrangement for static electricity discharge from MCV shall be made during loading and unloading of CNG from the cascade on the vehicle; and
- (xiv) Mobile cascade vehicles running on HSD shall be fitted with spark arrestors and the spark arrestors shall be valid and of mark approved by PESO.

7.0 CYLINDERS:

- 7.1 The cylinders and their fittings for CNG use shall be designed, manufactured, tested including hydrostatic stretch test at a pressure in full conformity to IS 7285-1, IS 7285-2, ISO 11119-1, ISO 11119-2, ISO 11119-3, ISO 11120, EN 12245, EN 12247 or other national or international standards having approval from statutory authority under Gas

Cylinder Rules, 2004 i.e. Petroleum and Explosives Safety Organisation considering the maximum allowable operating pressure of 250 bar.

- 7.2 These cylinders are to be permanently and clearly marked for “CNG only” and also labelled "CNG ONLY" in letter at least 25 mm high in contrasting colour in a location which shall be visible after installation.
- 7.3 The cylinder shall be fabricated from steel or composite materials as per the national or international design codes referred to in paragraph 7.1 or any other standard duly approved by the Petroleum and Explosives Safety Organisation.
- 7.4 The cylinders shall be re-examined or re-tested every three years and in accordance with Gas Cylinder Rules, 2004 by a competent person in line with the directives of the Petroleum and Explosives Safety Organisation with due markings and no cylinder shall be used which has not been duly re-tested as specified in.
- 7.5 Cylinders shall be painted white to reduce solar heating effect and protect it from atmospheric corrosion.

8.0 CNG PIPING OR TUBING:

- 8.1 All rigid piping, tubing, fittings and other piping components shall conform to the recommendations of ANSI B 31.3 and all the elements of piping should be designed for the full range of pressures, temperatures and loading to which they may be subjected with a factor of safety of at least 4 based on the minimum specified tensile strength at 20 deg. C.
- 8.2 Gaskets, packing and any other materials used shall be compatible with natural gas and its service conditions.
- 8.3 All the piping and tubing shall have minimum turns with adequate provision for expansion, contraction, jarring, vibration and settling and the exterior piping may be either buried with suitable corrosion protection or installed 30 cm. above the ground level with supports and protection against mechanical and corrosive damage.
- 8.4 Rigid pipelines shall have welded joints between their respective components.
- 8.5 All the piping and tubing shall withstand a pressure equal to that of safety relief device and tested accordingly after assembly and the testing to be done by inert gas and in case natural gas is used the suitable safety measures to be adhered to.
- 8.6 The fuel lines shall have a positive segregation with electrical cables.

8.7 VALVES:

- 8.7.1 A minimum of four shut off valves shall be fitted between the gas storage unit and vehicle refueling filling nozzle as explained below, namely: -

- (a) Each CNG storage unit to have quick action isolation valve in the steel supply pipe immediately adjacent to such storage unit to enable isolation of individual storage unit and such valves shall be within fencing of storage unit;
- (b) Master shut off valve with locking arrangement in close position, shall be installed in steel outlet pipe outside but immediately adjacent to the gas storage unit to isolate all downstream equipment from the gas storage unit and such valve shall be outside the fencing.
- (c) A quick action emergency and isolation shut off valve shall be installed near dispensing unit with easy approach and to remain closed when refueling is not being done; and
- (d) A vehicle refueling shut off valve shall be installed for each flexible vehicle refueling hose to control the refueling operation and shall have venting provision to allow for the bleeding of the residual high-pressure gas after refueling is complete.

8.7.2 All these valves and other elements of piping shall be suitable for the full range of pressure and temperature to which they may be subjected and such valves shall have permanent marking for service rating and like other markings.

9.0 CNG HOSES:

- 9.1 Internally braided, electrically continuous, non-metallic and metallic hoses resistant to corrosion and suitable to the natural gas service shall be used for CNG service in the downstream of emergency and isolation shut off valve.
- 9.2 The flexible hoses and their connections shall be suitable for most severe pressure and temperature service condition expected with a burst pressure of at least four times the maximum working pressure.
- 9.3 The flexible hoses with their connections shall be tested after assembly and prior to use to at least two times the working pressure and also tested to a pneumatic pressure of at least 400 bar under water and thereafter, all the hoses shall be examined visually and tested for leaks with soapsuds or equivalent at an interval not exceeding one year and hoses shall be rejected and destroyed in the event of any leakage and such tests are to be recorded and such records shall be available at installations at all times and such tests, examinations, rejections and destruction shall be done safely in a controlled environment by the trained technicians having adequate expertise with respect to the assembly of hoses, breakaways, valves and fuel nozzles.
- 9.4 Flexible hoses shall have permanent marking indicating the manufacturer's name or identification, working pressure and suitability for use with CNG.
- 9.5 CNG flexible electrically conductive hose shall be meeting the requirement as per NFPA-52 or NGV 4.2 or equivalent.

10.0 PRESSURE GAUGES:

- 10.1 Every CNG storage unit including each cascade or bulk storage tank shall be provided with a suitable pressure gauge directly in communication with them.
- 10.2 The CNG storage unit shall have an opening not to exceed 1.4-mm diameter at the connection where pressure gauge is mounted.
- 10.3 The pressure gauge shall have dial graduated to read approximately double the operating pressure but in no case less than 1.2 times the pressure at which pressure relief valve is set to function.
- 10.4 All pressure gauges in the installation shall be tested and calibrated atleast once a year and records maintained.

11.0 COMPRESSOR STATION:

- 11.1 The piping and its fittings upto the battery limit of CNG installation shall conform to ASME B 31.8 or equivalent.
- 11.2 Compressor shall be designed for use in CNG service and for the pressures and temperature to which it may be subjected under normal operating conditions conforming to API 618/ API 813 / API 11 P or equivalent standard and flame proof electric motor and associated fittings should conform to IS/IEC 60079 suitable for Gas Group IIA as applicable for Natural Gas.
- 11.3 Compressor shall be fitted with the following minimum devices; namely: -
 - (a) Pressure relief valves on inlet and all stages to prevent pressure build up above the predetermined set point;
 - (b) High discharge temperature shut down;
 - (c) High cooling water temperature switch fitted to cooling water return line to shut the compressor in the event of a fault;
 - (d) High, inlet, inter stage and discharge pressures shut down;
 - (e) Low lube oil pressure shut down;
 - (f) Low cooling water flow switch fitted to the cooling water return line to shut the compressor in the event of fault; and
 - (g) A remote isolation switch for emergency shut down to be provided with manual reset at control panel.
- 11.4 Compressor shall be provided atleast the following clear and permanent markings readily accessible and easy to read in the installed position; namely: -

- (a) Manufacturer's name;
- (b) Model;
- (c) Serial No. or month and year of manufacture
- (d) Certificate of approval no.;
- (e) Rated capacity (cubic meter per hour);
- (f) Operating speed (RPM);
- (g) Required driving power (in kW);
- (h) Maximum and minimum supply pressures;
- (i) Maximum outlet pressure; and
- (j) Certification for Natural Gas use.

11.5 A compressor and its all fittings shall be tested for compliance of relevant standard suitable for CNG use by a qualified engineer.

12.0 PRESSURE RELIEF DEVICE:

12.1 Safety Relief Devices may consist of either burst disc or safety relief valve and should conform to the requirements of API 520 or equivalent equipment design standards.

12.2 Safety relief devices shall be installed with unobstructed full size discharge to a safe place on bulk tanks and cylinders in the vertical position with suitable rain caps and such devices should have their outlet arranged in a manner so that in case of emergency a high-pressure gas escapes from the devices should not directly hit on operators or persons in the close vicinity.

12.3 Cylinder should have safety relief devices fitted in conformity to the Gas Cylinder Rules; 2004.

12.4 Piping shall be protected by safety relief devices in conformity to design standards.

12.5 Safety relief valves shall have a locking arrangement to prevent tampering by unauthorised persons and any adjustments to the safety relief valves shall be made by manufacturer or a competent person and such valves should have a permanent tag indicating pressure setting, date of re-setting or setting and capacity.

12.6 All safety relief devices shall be tested at least once a year for proper operations and records to be maintained.

12.7 All the safety relief devices shall have manufacturer's permanent marking indicating the following; namely: -

- (a) Set pressure to start discharge; and
 - (b) Discharge capacity in CuM / min.
- 12.8 No shut off valves shall be installed between the safety relief device and the gas storage unit or bulk tank.
- 12.9 All natural gas devices not otherwise specifically mentioned shall be constructed and installed to provide a safety equivalent to that other parts of the system.
- 12.10 Gas detectors interlocked with compressor cut out switch in the electrical system of the compressor are to be installed which would automatically switch off the unit in case of major gas leak.

13.0 ELECTRICAL EQUIPMENT:

- 13.1 All electrical wiring and equipment, gas storage dispensing unit located in hazardous area Division I and II shall be in accordance with the law in force relating to electricity, Gas Cylinder Rules,2004 and IS:5571, IS:5572, NFPA - 52.
- 13.2 The earthing at the installation, protection against ignition arising out of static, lightning and stray currents shall be the law in force relating to electricity.
- 13.3 The electrical power distribution system shall be as per paragraph 4.0 of Schedule 1.

14.0 SAFETY AT VEHICLE FOR REFUELING:

- 14.1 The vehicles shall have approved type of CNG kit fitted in accordance with the guidelines of Government of India, Ministry of Surface Transport, and authorised in a workshop conducted for such purpose and such workshop should issue a fitness certificate to the vehicle for its suitability for CNG use and such certificate should be always carried by the driver of the vehicle at all times.
- 14.2 Driver of the vehicle should also carry the record showing the last examination of the vital parts of the system fitted in the vehicle for CNG use and their next due date for such examination and such record must include the test periodicity of cylinder, pressure relief devices, pressure gauges, piping and other like requirements.
- 14.3 The cylinder with valves and connected facilities fitted in the vehicle shall be in accordance with Gas Cylinder Rules,2004 and such cylinder should be subjected to hydraulic test at least once every three years.
- 14.4 Every vehicle using CNG fuel system should display “CNG” labels prominently in compliance to the law in force relating to motor vehicle.

14.5 Manufacturing of Type-1 and Type 2 Nozzles shall be in accordance with NGV1 and ISO 14469-2 standards.

15.0 DISPENSING UNIT:

15.1 Dispensers shall be installed on a suitable foundation observing the minimum safety distances and like other precautions. as given in paragraph 4.2 and the dispensing unit to be protected against possible damage by vehicular movement and the dispenser mounting and installation shall be in accordance with NFPA 52 and NFPA30A or as per design standard.

15.2 The flexible hoses fitted on the dispenser shall be mechanically and electrically continuous and the design, material and construction of hoses shall be suitable for CNG and shall withstand not less than four times the maximum working pressure of the system.

15.3 The dispensing unit shall be of a type approved by the Petroleum and Explosives Safety Organisation or concerned Statutory Authorities.

15.4 Dispensing unit shall be suitable for use of CNG in accordance with NGV 4.1 and hoses as per NGV 4.2 and breakaway as per NGV 4.4.

16.0 CNG REFUELING INTO VEHICLES:

16.1 The vehicle refueling shall be done by an experienced operator duly certified by the oil or gas company having control over the refueling station.

16.2 The operator of the CNG dispensing unit shall check the following prior to refueling the gas, namely: -

(a) The driver of the vehicle is carrying updated history record as specified in paragraph 16;

(b) There is no smoking, naked flame or any other source of ignition within six meters of the refueling point';

(c) There is no leakage in the CNG fuel system reported by the driver of the vehicle;

(d) The fuel connection is in good condition and matches the dispensers filling nozzle and the fuel connection shall be tight without any leakage;

(e) The engine is switched off, hand brake is firmly applied, the vehicle parked in gear or in "P" with automatic transmission; and

(f) No passenger including crew remain inside the vehicle.

16.3 Detailed precautions (as specified in paragraph 18.2) and the procedure of refueling to be displayed near the dispensing unit and the same shall be strictly followed by the operator.

- 16.4 The operator of the dispensing machine should not leave the vehicle being refueled.
- 16.5 The cylinder on the vehicle shall not be charged in excess of maximum allowable working pressure at normal temperature for the cylinder.
- 16.6 Before the refueled vehicle is driven away from the dispensing point the operator and driver should ensure that there are no apparent gas leaks either on the vehicle or on the dispensing point that may have been caused through faulty filling or the faulty action of connecting or disconnecting.
- 16.7 Warning signs depicting "STOP VEHICLE", "NO SMOKING", "NO OPEN FLAME PERMITTED", "FLAMMABLE GAS", "NO MOBILE PHONE", "SWITCH OFF THE MOBILE PHONES" shall be displayed on suitable places at the dispensing station and compressor areas and the location of the signs shall be such that they are prominently visible from each point of the transfer or operation.
- 16.8 The operator shall take all measures for ensuring smooth vehicle movement in the outlet including restriction on number of vehicles near the fill points.

17.0 FIRE PROTECTION:

- 17.1 Fire fighting facilities need to be carefully planned after considering the availability of municipal fire tenders and other related matters and, at least the following portable fire extinguishers shall be positioned, namely: -

S. No.	Location	Type of Extinguishers
1	Dispensing Unit	1 x 9 kg. DCP / ABC with dial gauge.
2	Compressor (on-line)	1 x 9 kg. DCP/ ABC with dial gauge.
3	Mother station	1x 75 kg DCP.
4	CNG Storage	1 x 9 kg. DCP/ ABC with dial gauge.
5	Cascade refueling area	1 x 9 kg. DCP/ ABC with dial gauge.
6	MCC or Electrical Installation	1 x 4.5 kg CO2 Per 25 Sq. M floor area.

- 17.2 Any other flammable materials not specified in this standard in the CNG installation shall be stored in a non-flammable chamber with a minimum safety distance of 15 M from compressor station or MCC or electrical installation, as the case maybe.

- 17.3 All approaches to machines, compressors, storage facilities and work places shall be free from obstacles, so that they are readily accessible in an emergency.
- 17.4 The electrical installations shall be inspected by an Electrical Inspector as per IE Rules in force and compliance shall be made as pointed out in the inspection and the records shall be maintained for all periodic inspections.
- 17.5 The flameproof characteristics of electrical equipment shall be checked through visual checks, condition of gasket, completeness and tightness of bolts, glands and as recommended by manufacturer's test certificates.
- 17.6 The unauthorised additions or modifications of the service station whether temporary or permanent, which are not permissible or authorized under the law or the standards in practice, shall be taken up.
- 17.7 Proper illumination to be ensured for all operating and non-operating areas.
- 17.8 All electrical maintenance at the Automotive Station shall be undertaken by electrical technician licensed under law in force and under the supervision of authorised person in this behalf.
- 17.9 Each installation shall have minimum two numbers hand held explosive meter in working conditions at all times.
- 17.10 The work permit shall be issued by designated person and be followed and the Annexure – vi (A) and vi (B) in Schedule 1 shall be followed.

18.0 EMERGENCY PLAN AND PROCEDURE:

- 18.1 A comprehensive ERDMP shall be developed in accordance to the Petroleum and Natural Gas Regulatory Board (Codes of Practices for Emergency Response and Disaster Management Plan (ERDMP)) Regulations, 2010 and copies of the ERDMP shall be available to all personnel at the CNG dispensing station.
- 18.2 The entity having control over the refueling station shall draw an operational emergency plan in consultation with adjoining establishments and local authorities e.g. fire brigade, police, and other District Emergency Authorities and like other Authorities. for the following circumstances, namely: -
 - (i) Loss of or interruption to the gas supplies due to leaks or failure of pipeline;
 - (ii) Over-odorisation of the gas;
 - (iii) Major failure of CNG fittings;
 - (iv) Accidents or other emergencies, which can affect the CNG refueling, station;
 - (v) Civil emergencies;

- (vi) Emergency situations during transportation of CNG through mobile cascade vehicles;
and
 - (vii) Any other risk arising from the existence or use of the CNG refueling station.
- 18.3 The emergency plan specified in paragraph 18.2 shall be disseminated amongst all personnel involved to ensure that they understand their roles and responsibilities in the event of an emergency.
- 18.4 The operator of the refueling station should have close liaison with Fire Service, the Police, the Municipal Authorities and the person supplying gas to CNG facility.
- 18.5 Important telephone numbers for emergency use shall be displayed prominently.
- 18.6 Means of communication shall be always at the disposal of the In charge of the installation on 24 hours basis.
- 18.7 The emergency plan should be tested with drill at least once a year.

19.0 COMPETENCE ASSURANCE AND ASSESSMENT:

- 19.1 The objective is to provide good understanding of all the facets of dispensing activities including operations, procedures, maintenance and hazards of CNG and the risks associated with handling of the product and the training shall ensure that the jobs are performed in accordance with the laid down procedures and practices.
- 19.2 Every entity shall develop, implement, and maintain a written training plan to instruct all CNG dispensing station personnel with respect to the matters specified in paragraphs 19.2.1 to 19.3
- 19.2.1 Carrying out the emergency procedures that relate to their duties at the CNG dispensing station as set out in the procedure manual and providing first aid.
- 19.2.2 Permanent maintenance, operating, and supervisory personnel with respect to the following, namely: -
- (a) The basic operations carried out at the CNG dispensing station;
 - (b) The characteristics and potential hazards of CNG dispensing station and other hazardous fluids involved in operating and maintaining the CNG dispensing station, including the serious danger from frostbite that can result upon contact with POL products and CNG;
 - (c) The methods of carrying out their duties of maintaining and operating as set out in the manual of operating, maintenance and transfer procedures.
 - (d) Fire prevention, including familiarization with the fire control plan of the CNG dispensing station; fire fighting; the potential causes of fire or accident in CNG

dispensing station; the types, sizes, and likely consequences of a fire or accident at a CNG dispensing station; and

- (e) Recognizing situations when it is necessary for the person to obtain assistance in order to maintain the security of the CNG dispensing station.

19.2 Training shall be imparted to the staff attached with the CNG dispensing station at the time of induction, which is to be followed up by periodic refresher courses once every year and the training programme shall inter alia cover the following aspects, namely: -

- (i) Hazardous characteristics of CNG;
- (ii) Familiarisation with operational procedures and practices;
- (iii) Commissioning of new facilities and equipment;
- (iv) Hands on experience on operation of equipment;
- (v) Routine maintenance activities of the facilities;
- (vi) Knowledge of emergency and manual shut down systems;
- (vii) Immediate and effective isolation of any CNG leak;
- (viii) Accounting of product;
- (ix) Safety regulations and accident prevention;
- (x) Fire fighting facilities, methods of fire fighting and its upkeep;
- (xi) Evacuation and safe egress of the vehicles;
- (xii) Housekeeping;
- (xiii) Safety in transportation of CNG;
- (xiv) First aid;
- (xv) Emergency plan or drills;
- (xvi) Natural gas leakage possibility and its containment;
- (xvii) Filling nozzles, types of gasket or seal and like device for joining; and
- (xviii) Access control of vehicles so as to allow the vehicle with tested cylinders to be filled with CNG.

19.3 Appropriate training techniques shall be adopted which will include the following, namely:

-

- (a) Classroom training;
- (b) Hands on or practical training;
- (c) Demonstration;
- (d) Case studies; and
- (e) Training aids.

19.4 Proper records for the training and refresher courses shall be maintained at the installation.

20.0 Automation:

The automation (Forecourt Control) where provided, shall comply with the provisions as specified paragraph 5.0 of Schedule 1.

21.0 SAFETY INSPECTIONS OR AUDIT:

The safety inspections or audit of CNG dispensing station shall be carried out as given below, namely: -

TYPE	FREQUENCY	AGENCY
General Inspection	Daily	Operating personnel
	Twice in a quarter	Authorised personnel of marketing company
Safety Audit	Once in a year	Authorised Person
Electrical Audit	Once in three years	Licensed Electrical agency

Note: - The comprehensive checklist shall be developed in line with the similar checklists provided in Schedule 1.

22.0 List of Standards or Guidelines referred to in Schedule 3 shall be as given in Annexure I.

ANNEXURE - I

REFERENCES

S. No	Ref Code No.	Title
1	GCR 2004	Gas Cylinder Rules 2004 under The Explosives Act 1884 of Government of India
2	IS 15958 (2012)	Compressed Natural Gas (CNG) for Automotive Purposes - Specification
3	IS 15320-1 (2012): ISO 15403-1 : 2006	Natural Gas – Natural Gas for use as a Compressed Fuel for Vehicles, Part 1: Designation of the Quality
4	IS 7285-1 (2004):	Refillable Seamless Steel Gas Cylinders, Part 1: Normalized Steel Cylinders
5	IS 7285-2 (2004):	Refillable Seamless Steel Gas Cylinders, Part 2: Quenched and Tempered Steel Cylinders with Tensile Strength Less Than 1 100 MPa (112 kgf/mm ²)
6	IS 1642 (1989):	Code of practice for fire safety of buildings (general): Details of construction
7	IS 875- Part 1 to 5 (1987):	Code of Practice for Design Loads (Other than Earthquake) for Buildings and Structures
8	IS 1893 (Part 1) 2002	Criteria for Earthquake Resistant Design of Structures,
9	IS 800	General Construction In Steel
10	IS:5571	Guide for selection of electrical equipment for hazardous areas
11	IS:5572	Classification of Hazardous areas (other than mines) having flammable gases and vapours for electrical equipment.
12	IS/IEC 60079- (2007):	Explosive Atmospheres, Equipment Protection
13	NFPA 12	Standard on Carbon Dioxide Extinguishing Systems
14	NFPA 17	Standard for Dry Chemical Extinguishing Systems
15	NFPA 52	Vehicular Gaseous Fuel Systems Code
16	ISO 11439:2013	Gas cylinders - High pressure cylinders for the on-board storage of natural gas as a fuel for automotive vehicles
17	ISO 11119-1	Gas cylinders--Gas cylinders of composite construction-- Specification and test methods--Part 1: Hoop-wrapped composite gas Cylinders
18	ISO 11119-2	Gas cylinders—Gas cylinders of composite construction— Specification and test methods—Part 2: Fully wrapped fibre reinforced composite gas cylinders with load-sharing metal liners
19	ISO 11119-3	Gas cylinders of composite construction - Specification and test methods - Part 3: Fully wrapped fibre reinforced composite gas cylinders with non-load-sharing metallic or non-metallic liners
20	ISO 11120	Gas cylinders - Refillable seamless steel tubes of water capacity between 150 L and 3000 L Design, construction and testing

21	EN 12245	Transportable gas cylinders - Fully wrapped composite cylinders
22	EN 12257	Transportable gas cylinders - Seamless, hoop-wrapped composite cylinders
23	CGA TB-25	Design Considerations For Tube Trailers
24	NZS5425: Part 1:1980	Code of Practice for CNG Compressor and Refueling Stations Part 1: On Site Storage and Location of Equipment.
25	NZS5425: Part 2:1982	Code of Practice for CNG Compressor and Refueling Stations Part 2: Compressor Equipment.
26	Petroleum Rules 2002	The Petroleum Rules 2002 under Petroleum Act 1934, Govt of India
27	CCOE Guidelines	Chief Controller of Explosives, Govt. of India, for CNG Refueling Stations.
28	ISO 6346	Coding, Identification and Marking of Containers: International Container Bureau (BIC).

**“SCHEDULE 4:
[See Regulation 6 (4)]**

Storage, Handling and Dispensing at LNG and LCNG Dispensing Stations

1.0 Scope

1. The technical standard and specifications including safety standards under this Schedule lays down the minimum requirements in design, storage, transportation, operation, inspection, maintenance, training, consumer safety at Retail Outlets dispensing LNG or LCNG with above ground pressurized LNG storage. It does not cover the certification or fitness requirements of vehicles.
2. These provisions shall apply to the following—
 - a. The requirements of the design, fabrication and installation and commissioning of LNG storage facility using cryogenic vacuum insulated containers of double wall constructed in accordance with approved pressure vessel codes and the requirements for safe vaporization, transfer and handling.
 - b. The requirements of the road transportation of LNG in a cryogenic double walled vacuum insulated pressure vessel for the safe transportation and handling.
 - c. Dispensing stations with following variants, namely:
 - i. Dispensing of LNG;
 - ii. Dispensing of CNG (LCNG);
 - iii. Provision for connection for supply of PNG; and
 - iv. Filling of CNG cascades.
3. These facilities can be standalone or any combination of above or co located with Petroleum that is to say i.e. MS, HSD dispensing stations

2.0 Definitions

- i. “Auto LNG” means a liquefied natural gas (LNG) Meant for automotive fuel;
- ii. “Auto LNG dispensing station” means any premises used for storing and dispensing auto LNG as automotive fuel to the motor vehicles;
- iii. “LCNG” means CNG produced at the fueling station from LNG by pumping and vapourisation;

- iv. "Impounding area" means an area that may be defined through the use of dykes or the topography at the site for the purpose of containing any accidental spill of LNG or flammable refrigerants;
- v. "Dyke" means a structure used to establish an impounding area.

3.0 Storage Installations and Handling

3.1 Installation Layout and General Requirements:

1. For the pressurized LNG storage installations:

- a. The minimum safety distances between the LNG storage vessels and then nearest building or line of adjoining property shall be in accordance with the distances specified in Table (1) of this schedule. The maximum aggregate capacity of each such LNG installation shall not exceed 1060 m³.

The minimum distance between vessel and dyke wall, minimum distances between equipment or/ items installed outside the dyke wall and outer edge of dyke wall, the minimum distance between various facilities at LNG or LCNG dispensing stations are respectively specified in Table-2, Table-3 and Table-4 of this Schedule.

TABLE-1

DISTANCES FROM IMPOUND WALL AND PROPERTY LINE

Sl. No.	Water Capacity of the largest vessel (m ³)	Minimum distance from edge of impoundment or vessel drainage system to property line	Minimum distance between storage vessels
1	< 0.5	0 m	0
2	> 0.5 but ≤ 1.9	3 m	1 m
3	> 1.9 but ≤ 7.6	4.6 m	1.5 m
4	>7.6 but ≤56.8	7.6 m	1.5 m
5	>56.8 but ≤ 114.0	15.0 m	1.5 m
6	>114.0 but ≤ 265	23.0 m	1/4 of the sum of the diameters of adjacent vessel (minimum 1.5 m)
7	>265.0 but ≤379	es the vessel diameter (minimum 30.0 m)	

NOTE: The minimum separation distance shall be 100 meters between outer wall of the installation and nearest property line of mass gathering places such as school, hospitals and like other places

TABLE-2
MINIMUM DISTANCE BETWEEN VESSEL AND DYKE WALL

Sl. No.	Water capacity of vessel (m ³)	Inner edge of the dyke wall and outer shell of the storage vessel or D/2(whichever is higher)
1.	Not above 3.8	0.5 m
2.	Above 3.8 but not above 7.6	1.0 m
3.	Above 7.6 but not above 56.8	1.5 m
4.	Above 56.8 but not above 114.0	1.5 m
5.	Above 114.0 but not above 265.0	1/4 of the sum of the diameters of adjacent vessels (minimum 1.5 m)
6.	Above 265.0 but not above 379	

TABLE-3
MINIMUM DISTANCE (s) BETWEEN EQUIPMENT OR ITEMS INSTALLED OUTSIDE THE DYKE WALL AND OUTER EDGE OF DYKE WALL

Sl. No	Equipment or Items	Dyke wall (Outer Edge)
1.	Property Line or Fencing	As per Table 1 of this schedule
2.	Center of Truck Unloading Platform	Min. 4.0 m from dyke wall and min 9 m from the adjoining property. The fill point shall also observe minimum 9.0 meter safety distance to the adjoining property.
3.	Priority Panel	Outside dyke wall
4.	CNG Cascade (For LCNG station)	The safety distance as per Table II of Schedule-3 of these regulations. The

		cascade shall be segregated from LNG facility by providing concrete wall up to the height of the cascade.
5.	On site building/ Control room/sales office	Outside the safety distances as per Table 1 of this schedule.
6.	LNG and CNG Dispensers (if LCNG station)	Min. 6.0 m (and also, min 6.0 m from centre of hard stand).
7	Odorising tank	Min. 1.5 meters clear distance from all other facilities.

NOTE: The above facilities can be either standalone or co-located. The minimum distance between dispenser, fill point, impounding or dyke wall, vent etc. shall be as per Table -4 of this Schedule.

Table - 4

The minimum distance between various facilities at LNG or LCNG dispensing stations

Sr. No	Station	Inter Distance/ Norm	Distance (Mtr)
A	Dispensing Stations not co-located with Petroleum Retail outlets		
1	Standalone (LNG or LCNG)	Auto LNG or LCNG Dispenser and Property line	6
		Auto LNG or LCNG Dispenser and Impound Wall	6
2	LNG and LCNG	Auto LNG and LCNG Dispenser	6
3	LNG, LCNG and Cascade Filling	Mobile CNG Cascade Filling Point and LNG or CNG Dispenser	6
		The cascade shall be segregated from the LNG facility by providing concrete wall upto height of cascade.	-
4	Auto LNG, LCNG, Cascade filling and	Shall comply with the PNGRB T4S for CGD Networks Regulations for connection for supply of PNG	-

	connection for supply of piped gas		
B	Dispensing Stations Co-located with Petroleum Retail Outlets		
5	LNG or LCNG dispensing at Retail Outlet	LNG or LCNG and MS or HSD Dispenser	6
6		MS or HSD fill point and Impound wall	9
7		MS or HSD Vent and Impound wall	9
8		MS or HSD fill point or Vent and Auto LNG or LCNG Dispenser	9
9		Center of LNG Truck unloading platform (Hard stand) to MS or HSD Vent or Fill point	9

NOTE: NON FUELING FACILITIES AT LNG OR LCNG STATIONS -

- (1) Non fueling facilities like small convenience stores, service station, ATM, PCO, whenever provided, shall be beyond safety distance mentioned in this Schedule. In addition, a minimum distance of 10 meter from the LNG or LCNG dispensers shall be maintained. The accessibility to such non fuelling facilities shall not be through operational area. While providing such facilities, factors like degree of congestion in the premises, easy entry and exit of the vehicle coming for refueling and easy maneuverability of LNG road tanker while moving out of the premises in the event of emergency shall also be taken into consideration,
 - (a) For non-pressurized LNG storage installation,
 - (b) The safety distances specified in the PNGRB (Technical Standards and Specifications including Safety Standards for LNG Facilities) Regulations, as amended from time to time, shall be followed.
- (2) The LNG installation shall be designed to withstand the following without loss of structural or functional integrity, namely -
 - (a) The direct effect of wind forces;
 - (b) Seismic effect;
 - (c) Erosive action from a spill;
 - (d) Effect of the temperature, thermal gradient, and any other anticipated degradation resulting from sudden or localised contact with LNG;
 - (e) weight effects of components and fluids (hydrostatic head);
 - (f) effect of soil settlement or aquifer (ground water level); and
 - (g) transport and erection load.
- (3) The structural members of the impoundment system shall be designed and constructed to prevent impairment of reliability and structural integrity as a result of the following,

namely-

- (a) Imposed loading from full hydrostatic head of impounded LNG;
 - (b) Effect of rapid cooling to the temperature of liquid to be confined;
 - (c) Fire exposure; and
 - (d) Natural forces (Earthquake, wind, rain and like other natural forces)
- (4) Impoundment or dyke areas shall be designed to prevent water collection. Drainage pumps and piping should be provided to remove water from collecting in the impoundment area. Where drainage pumps with automatic controls are used, these shall be provided with cut off devices that prevent their operation when exposed to LNG storage temperature.
 - (5) Compressors, CNG Cascades, Odorizers and like other devices shall not be located inside the impounding area.
 - (6) Odorizing unit shall be provided in LCNG stations.
 - (7) The ambient air vaporizers and remotely heated vaporizers may be located inside impounding area.
 - (8) The impounding system for LNG storage vessel shall have a minimum 110 % of the volumetric capacity of the largest vessel in an impoundment.
 - (9) The height of the impoundment wall shall be adequate to contain spillage of LNG. Dyke wall height should be between 0.6 meter to 1 meter from the dyke floor level.
 - (10) Height of the foundation of the vessel shall be minimum 0.4 meter or designed in such a way to prevent exposure of carbon steel material to the spilled LNG.
 - (11) All the discharge lines of relief valves, vent valve, bleed valves and like other devices shall be connected to a vent stack which shall vent at a safe height such that no Lower Flammability Level is formed at the ground level during release of LNG.
 - (12) No other flammable liquid or storage vessel shall be located within an LNG impounding area.
 - (13) A clear space of 0.9 meters shall be provided for access to all isolation valves serving multiple vessels. The isolation valve of LNG vessel piping should be close to outer vessel.
 - (14) LNG vessels, cold boxes, piping and pipe supports and other cryogenic apparatus installed within dyke shall be designed and constructed in a manner to prevent damage to these structures and equipment due to freezing or frost heaving in the soil.
 - (15) Adequate flameproof lighting conforming to IS 2206 or equivalent shall be provided for facilities transferring LNG during night. For layout and installation of electrical equipment, paragraph 4.3 of Schedule – 1 of these regulations shall be referred.
 - (16) Electrical grounding and bonding shall be provided in line with IS 3043. For further details, paragraph 4.4 of Schedule – 1 of these regulations shall be referred.
 - (17) Layout shall ensure unobstructed access and exit of the consumers and vehicles including

LNG tankers, CNG cascades and like other devices as applicable at all times.

- (18) Entrance, exit and paving shall be arranged in a manner, so as to minimize the risk of collision. Crash or impact barriers shall be installed to protect vulnerable equipment against accidents involving vehicles.
- (19) The operating personnel shall have an unobstructed overall view of the facilities both from the sales room and from the delivery area. In case of any obstruction during vehicle unloading and like other activities CCTV with UPS should be provided for the view of the facilities.
- (20) Personal Protection:
Every person handling any operations involving LNG shall always wear appropriate personal protective equipment (PPE) not limited to-
 - (i) Face shield;
 - (ii) Safety goggles;
 - (iii) Thermal Insulated Gloves;
 - (iv) Cover-all – covering “head to toe” or protective apron;
 - (v) Safety Shoes; and
 - (vi) Safety Helmet
- (21) The designated location for tanker unloading shall not hinder other traffic. The tanker shall always be placed in drive out position.
- (22) Crash or impact barriers shall be installed to protect dispensing units against accidents involving vehicle movements.
- (23) The storage area which includes the pumps and the related piping shall be suitably segregated from the rest of the premises and located in a manner that it is away from the area frequented by public during their movement within the station and also from the path of vehicles entering and leaving the premises.
- (24) Typical layouts of auto LNG or LCNG Station with provision of mobile cascade filling and PNG and auto LNG or LCNG dispensing Station co-located with Petroleum (MS, HSD) Retail outlet provided in Layout– I and Layout– II respectively of this Schedule.

4.0 LNG Storage Vessel -General design requirements:

- (1) Foundation:
 - (a) LNG vessels foundations shall be designed and constructed in accordance with established or approved engineering practices. Prior to the start of design and construction of the foundation, a subsurface investigation shall be conducted to determine the stratigraphy and physical properties of the soils.
 - (b) The design of saddles and legs for the LNG vessel shall include erection load, wind loads thermal loads and seismic loads.
 - (c) Foundation and support shall have a fire resistance rating of not less than two

hrs. Support up to 0.4 meter may not need fire proofing.

- (d) LNG vessels installed in areas subject to flooding shall be secured to prevent release of LNG or floatation of the vessel in the event of a flood.

(2) Vessel Design:

- (a) The vessel meant for storage of LNG including piping between inner and outer vessel shall be designed in accordance with ASME Section VIII Div I and / EN13458 / ASME: B.31.3, process piping or equivalent code.
- (b) The inner vessel shall be designed for the most critical combination of loading resulting from internal pressure, liquid heads. The Inner vessel supports system shall be designed for shipping, seismic, and operating loads.
- (c) The outer vessel shall be equipped with a relief or other device to release internal pressure and shall have discharge area of at least $0.34 \text{ mm}^2/\text{liter}$ of the water capacity of the inner vessel but not exceeding 2000 cm^2 and have pressure setting not exceeding 25 psi (1.72 Kg/cm^2).
- (d) Thermal barriers shall be provided to prevent outer tank from falling below its design temperature.
- (e) Those parts of LNG vessels which come in contact with LNG and all materials used in contact with LNG or cold LNG vapor shall be physically and chemically compatible with LNG and intended for service at $-162 \text{ }^\circ\text{C}$. In case, commissioning is done with liquid nitrogen, argon and like other gases, then, all materials and parts shall be compatible with their respective boiling temperature.
- (f) All piping that is a part of LNG vessel including all piping internal to the vessel, within void space, and external piping connected to the vessel up to the first circumferential external joint of the piping shall be in accordance with ASME Boiler and Pressure Vessel Code, Section VIII or ASME B 31.3 or equivalent.
- (g) LNG vessels shall be designed to accommodate both top and bottom filling unless other positive means are provided to prevent stratification.
- (h) Any portion of the outer surface area of an LNG vessel that could accidentally be exposed to low temperatures resulting from the leakage of LNG or cold vapor from flanges, valves and like other devices, shall be intended for such temperatures or protected from the effects of such exposure.
- (i) Seismic loads shall be considered in the design of the LNG vessel support systems.
- (j) To avoid excessive BOG generation, suitable insulation shall be provided. Vessel jacket and insulation shall remain functional during fire for its design rating.

5.0 Fitments:

- (1) Each LNG double walled vessel shall have at least 2 numbers of safety relief valves capable of achieving the required relief capacity on standalone basis and shall be sized to relieve the flow capacity determined for the largest single contingency or any reasonable and probable combination of contingencies and shall include conditions

resulting from operational upset, vapor displacement and flash vaporization.

- (2) Relief devices shall be vented directly to the atmosphere. Each safety relief valve for LNG vessel shall be able to be isolated from the vessel for maintenance or other purposes by means of a manual full opening stop valve or a flow diverter valve. Valves shall be provided to allow each relief valve to be isolated individually for testing or maintenance whilst still maintaining the full capacity of the relief valve or valves in any position of the closing valve system (that is to say a full-port-opening three-way valve).
- (3) Safety relief valve shall be designed and installed to prevent any accumulation of water, or other foreign matter at its end.
- (4) The minimum pressure relieving capacity in kg/hr shall not be less than 3% of the full tank contents in 24 hours.
- (5) All liquid connections to the LNG vessel except relief valve and instrumentation connection shall be equipped with automatic fail safe product retention valves.
- (6) The automatic shut off valves shall be designed to close on occurrence of any of the following conditions, namely: -
 - (i) fire detection;
 - (ii) uncontrolled flow of LNG from vessel;
 - (iii) manually and remotely operated;
 - (iv) gas detection;
 - (v) high pressure trip on storage tank; and
 - (vi) high level trip on storage tank.
- (7) In case trailer mounted pump are used for unloading of LNG from the tanker, ESD interlink shall be provided to stop the discharging of LNG in case of rupture of the transfer system.
- (8) Automatic shutoff valves that require excessive time to operate during emergency that is to say sizes exceeding 200mm shall be pneumatically operated and also have means of manual operation.
- (9) LNG vessels shall have a device that prevents the vessel from becoming liquid full or from covering the inlet of the relief valve with liquid when the pressure in the vessel reaches the set pressure of relieving device under all conditions. The density of the product shall be considered at design temperature for calculating the ullage.
- (10) LNG vessel should be provided with one independent high liquid level alarm which can be part of the liquid level gauging devices, but the high liquid level flow cutoff device shall not be considered as a substitute for the alarm. High pressure trip (set below RV set point) shall be provided to detect overpressure (due to overfill)
- (11) LNG vessel shall be equipped with at least one liquid level gauging device. The devices shall be designed and installed so that they can be replaced without taking the tank out of operation. The level and pressure shall be visible to the operating personnel during unloading or loading and transfer.

- (12) LNG vessel shall be equipped with a high liquid level flow cut off device.
- (13) LNG vessel shall be equipped with pressure gauge connected to the vessel at a point above the maximum intended liquid level. Pressure transmitter shall be provided for initiating ESD.
- (14) Instrumentation for storage and vaporization facilities shall be so designed so that if a power or instrument air failure occurs, the system will proceed to a failsafe condition and maintain that condition until the operator takes appropriate action to reactivate or secure the system.

6.0 Equipment

- (1) Pumps employed in LNG source shall be provided with a pressure relieving device on the discharge to limit the pressure to the maximum safe working pressure of the casing and downstream piping and equipment.
- (2) Each pump shall be provided with adequate vent, relief valve, or both to prevent over-pressuring the pump casing during the maximum possible rate of cool down.
- (3) Pressurized vaporizers shall be designed, fabricated and inspected as per the requirements of ASME Boiler and Pressure Vessel Code, Section VIII Div. 1 or any other equivalent code.
- (4) The material of construction of LNG vaporizers is recommended as Austenitic Stainless-Steel piping with outer Aluminum fins. Ambient air vaporizers shall be of stainless steel with aluminum outer shell.
- (5) Manifolded vaporizers shall be provided with both inlet and discharge block valves for each set of vaporizer
- (6) The discharge valve of each vaporizer and the piping components and relief valves installed upstream of each vaporizer outlet valve or spec break flange, shall be designed for operation at LNG storage temperature. Each vaporizer shall have a relief valve at the outlet sized for the maximum vaporizer capacity flow. In case of spec break after vaporizer, sufficient low-temperature trip shall be installed to prevent embrittlement risk downstream of the spec break.
- (7) Two inlet valves shall be provided to isolate an idle and manifolded vaporizer to prevent leakage of LNG into the vaporizer. A safe means of disposing LNG or gas that can accumulate between the valves shall be provided in case the vaporizers are of size having inlets more than 50 mm diameter.
- (8) (i) The ambient air vaporizers shall be installed inside the impounding area.
 - (ii) Where the heated vaporizer is located 15 m or more from the heat source, the remote shutoff location shall be at least 15 m from both the vaporizer and heat source.
 - (iii) Where the heated vaporizer is located less than 15 m from the heat source or nearest LNG vessel, it shall have an automatic shut off valve in the LNG liquid line located at least 3 m from the vaporizer and shall close when either of the following occurs, namely:

- (1) Loss of line pressure (excess flow).
 - (2) The occurrence of a fire is detected by an instrument designed for the purpose and located to detect a fire in the covered area or abnormal temperature sensed in the immediate vicinity of the vaporizer (fire)
 - (3) Low temperature in the downstream of the vaporizer.
 - (4) Manual ESD trip, If the facility is attended, manual operation of the automatic shut off valve shall be at least 15 m away from the vaporizer, in addition to the requirement as specified in para(iii) above.
- (iv) The above conditions in foregoing clauses shall be applicable for LNG vaporizers for purposes other than pressure building coils or LNG to CNG (LCNG) systems.
- (9) A distance of minimum 1 meter shall be maintained between vaporizers.
 - (10) Any ambient vaporizer installed within 15 meters of the LNG vessel shall be equipped with an automatic shutoff valve in the liquid line. This valve shall be located minimum at least 3 meters from the vaporizers and shall close when loss of line pressure occurs or abnormal temperature is sensed in the immediate vicinity of the vaporizer or when low temperature in the vaporizer discharge line occurs.
 - (11) Each set of vaporizer shall be provided with a safety relief valves sized in accordance with the following requirements, namely:-
 - (i) Ambient vaporizers–relief valve capacity shall allow discharge equal or greater than 150% of the rated vaporizer natural gas flow capacity without allowing the pressure to rise 10% above the vaporizer maximum allowable working pressure; and
 - (ii) Relief valves on heated vaporizers – same as clause (a), but, it shall be located such that they are not subjected to temperatures exceeding 60°C. during normal operation.
 - (12) Automation shall be provided to prevent the discharge of either LNG or vaporizer gas into a distribution system at the temperature either above or below the design temperature of the send out system.
 - (13) Vaporizers shall be provided with outlet temperature monitors.
 - (14) Aluminium shall be used only downstream of a product retention valve in vaporizer service.

7.0 Piping System:

- (1) All piping system and components shall be designed to –
 - (a) Accommodate the effects of thermal cycling fatigue to which the systems shall be subjected;
 - (b) Provide for expansion and contraction of piping and piping joints due to temperature changes; and
 - (c) Meet the requirements of ASME 31.3.

- (2) Piping material including gaskets and thread compounds shall be compatible throughout the range of temperature to which they are subjected.
- (3) The valves provided in the installation shall be of extended bonnet type with packing seals in a position that prevents leakage or malfunction due to freezing.
- (4) Shut-off valves shall be provided for all vessel connections except connections for liquid level alarms and connections that are blind flanged or plugged.
- (5) All the piping section between the two valves where the liquid may be trapped shall have the thermal relief valve.

8.0 Transfer of LNG:

- (1) Isolation valves shall be installed so that each transfer system can be isolated at its extremities. Where power-operated isolation valves are installed, an analysis shall be made to determine the closure time so that it does not produce a hydraulic shock capable of causing line or equipment failure.
- (2) Adequate check valves shall be provided to prevent backflow and shall be located as close as practical to the point of connection to any system from which backflow might occur.

9.0 Pump and Compressor Control:

In addition to a locally mounted device for shutdown of the pump or compressor drive, a readily accessible, remotely located device shall be provided at least 7.5 meters away from the equipment to shut down the pump in an emergency.

10.0 Tank Vehicle Unloading Facilities:

- (1) The tank vehicle unloading area shall be of sufficient size to accommodate the vehicles without excessive movement or turning.
- (2) Transfer piping, pumps, and compressors shall be located or protected by barriers so that they are safe from damage by vehicle movements.
- (3) Isolation valves and bleed connections shall be provided at the unloading manifold for both liquid and vapour return lines so that hoses and arms can be blocked off, drained of liquid, and depressurized before disconnecting. Bleeds or vents shall discharge in a safe area.
- (4) At least one qualified person (usually the LNG tanker driver) shall be in continuous attendance and shall have an unobstructed view of the LNG transfer point while offloading is in progress. This person shall be able to monitor the level and pressure of the LNG storage tank and control the offloading process.
- (5) Written procedures shall be available to cover all transfer operations and shall cover emergency as well as normal operating procedures.
- (6) Loading and unloading areas shall be posted with signs that read "No Smoking."
- (7) Prior to transfer, gauge readings shall be obtained or inventory established to ensure that the receiving vessel cannot be overfilled, and levels shall be checked during transfer

operations.

- (8) The transfer system shall be checked prior to use to ensure that valves are in the correct position, and pressure and temperature conditions shall be observed during the transfer operation.
- (9) LNG vehicle engine shall be switched off during dispensing.
- (10) Restricting incoming traffic (such as closing the station during LNG unloading or offloading).
- (11) Implement exclusion zones during loading and unloading of LNG
- (12) The vehicle shall be earthed before start of the unloading.
- (13) Specific SOP shall be developed for unloading the LNG, complied with and always available at installation There shall be proper arrangement to handle spillage of LNG.
- (14) The Spark arrestor shall be provided.
- (15) Wheel chock should be used during unloading of vehicles.
- (16) Valve open-close system and electrical connection to be check once in two weeks.
- (17) 6 sq.mm braided copper wire with one end firmly bolted to the unloading facility and the other end provided with G.I crocodile clips are to be used for tanker grounding.
- (18) Transfer operations shall be commenced slowly and if any unusual variance in pressure or temperature occurs, transfer shall be stopped until the cause has been determined and corrected.
- (19) Pressure and temperature conditions shall be monitored during the transfer operation.
- (20) While tank vehicle unloading operations are in progress, vehicle traffic shall be prohibited within 25 ft (7.6 m) of LNG facilities or within 50 ft (15 m) of refrigerants whose vapors are heavier than air.
- (21) Truck vehicle engines shall be shut off if not required for transfer operations.
- (22) The engine shall not be started until the truck vehicle has been disconnected and any released vapors have dissipated.

11.0 Emergency Shut Down System (ESD System):

- (1) Each LNG facility shall incorporate an ESD system that when operated isolates or shuts off sources of LNG and shuts down equipment that add or sustain an emergency, if continued to operate.
- (2) The ESD system shall be of a failsafe design and shall be installed, located or protected from becoming inoperative during an emergency or failure at the normal control system.
- (3) ESD system shall have following features, namely:
 - a) alarm horn sounds (for at least 5 min);
 - b) alarm beacon turned on;

- c) offload pump stopped (if running);
 - d) dispensing pumps stopped and dispensing valves closed (if running);
 - e) dispensing valves closed (if dispensing);
 - f) dispensing recirculation valves closed at each dispenser; and
 - g) The ESD valve should close within 5 seconds of its actuation.
- (4) Initiation of the ESD system shall be manual, automatic, or both manual and automatic. Manual actuators shall be located in an area accessible in an emergency and at least 15 meters away from the equipment they serve, and shall be distinctly marked with their designated function.
- (5) Manual ESD valves shall be at least available
- a. at each dispenser;
 - b. on the control panel in control room;
 - c. near LNG truck off-loading point;
 - d. on the exterior wall of the control building adjacent to the door.
- (6) ESD system shall be designed in accordance with IEC 61511 or IEC 61508 or equivalent.

12.0 Fire Prevention and Protection Facilities:

- (1) Each LNG storage facility shall be provided with methane gas detectors, spill detectors and flame detectors which shall activate visual and audible alarms at the plant site and at constantly attended location if the facility is not attended continuously.
- (2) Flammable (Hydrocarbon) gas detection system shall activate an audible and a visual alarm at level not higher than 20 % of the LEL of the gas being monitored and trip the system at 40 % of LEL.
- (3) Fire detectors shall activate an alarm at the site and at a constantly attended location if the plant site is not attended continuously. If determined by an evaluation that it is necessary, then, fire and gas detectors shall be permitted to activate the ESD system.
- (4) Fire fighting facilities need to be carefully planned after considering the availability of municipal fire tenders and other related matters and, at least the following portable fire extinguishers shall be positioned, namely: -

Sr. No.	Location	Type of Extinguishers
1	Storage and decantation area	1 x 75 kg. DCP / ABC with dial gauge

2	LNG or LCNG Dispensing forecourt	1 x 75 kg. DCP / ABC with dial gauge
3	MCC or Electrical Installation	1 x 4.5 kg CO ₂ Per 25 Sq. M floor area

- (5) Portable or wheeled fire extinguishers of DCP or foam type shall be made available at strategic locations. At least 4 such extinguishers of 10 kg. capacity each shall be provided.
- (6) Additionally, two sets of sand buckets each comprising at least 4 sand bucket shall be provided at strategic locations.
- (7) These facilities shall be in addition to the fire firefighting facilities required for standalone dispensing stations as given in Schedule - 1 and Schedule-3.
- (8) Fire protection shall be provided for all LNG or LCNG fueling facilities. The extent of such protection shall be determined by an evaluation based on sound fire protection engineering principles, analysis of local conditions, vehicle operations hazards within the facility, exposure to or from other property, and the size of the LNG containers. The evaluation shall determine the following, as a minimum, namely-
 - i. The type, quantity, and location of equipment necessary for the detection and control of fires, leaks, and spills of LNG, flammable refrigerants, or flammable gases or liquids;
 - ii. The methods necessary for the protection of vehicles, equipment, and structures from the effects of fire exposure;
 - iii. The equipment and processes to be incorporated within the emergency shutdown (ESD) device system;
 - iv. The type, quantity, and location of sensors necessary to initiate automatic operation of the ESD system;
 - v. The availability and duties of individual facility personnel and the availability of external response personnel during an emergency; and
 - vi. The protective equipment and special training required by personnel for emergency duties.

13.0 Boil Off Gas Management

- (1) Management of BOG system shall be in place.
- (2) When LNG station is being set up, the capacity of storage tank may be optimized so as to minimize the BOG venting. For effective BOG management, the operator may use the gas for alternative supplies like CGD to avoid venting with the approval of the Competent Authority.

14.0 LNG or LCNG Dispensing

This paragraph lays down the requirements for LNG dispensers as below, namely: -

(A) General:

- (1) LNG dispensing sites dispensing saturated LNG with personnel in the immediate

vicinity shall provide barrier walls or equal protection in order to protect the dispensing operator and vehicle. A pulsed dead-man control system may be provided which ensures stopping of dispensing operation within 3 seconds of release of dead man trigger. The timer system of the control unit may require periodic actuation so that the control ensures presence of personnel throughout the operation. Break-away device in case of drive away with connected hose shall be provided;

- (2) All facility piping other than the dispensing hose to the vehicle shall be behind a barrier, which in the case of an equipment or device malfunction deflects the saturated LNG upward; and
- (3) LNG fueling facilities transferring LNG during the night shall have permanent, adequate lighting at points of transfer and operation.

(B) System Components:

(1) Vehicle Fueling Dispenser:

- (a) The dispenser shall be protected from damage due to vehicle collision using preventive barriers such as impact crash barriers, dispenser islands at height and traffic routing, allowing only one-way traffic and like other arrangements;
- (b) The maximum delivery pressure at the fueling nozzle shall not exceed the maximum allowable working pressure of the vehicle fuel tanks. A high-pressure trip in dispenser and discharge pump shall be provided;
- (c) (i) Hose or arms shall be equipped with a shutoff valve at the fuel end and a breakaway device to minimize release of liquid and vapour in the event that a vehicle pulls away while the hose remain connected;
(ii) Such a device shall be installed and maintained in accordance with the OEM's maintenance or safety instructions; and
(iii) A breakaway device shall be provided to separate using a force not less than 102 kgf and not greater than 125 kgf where applied in any direction that the vehicle would move;
- (d) The hose shall be secured to protect it from damage when not in use;
- (e) (i) Where a hose or arm of nominal 76 mm diameter or larger is used for liquid transfer or where one of nominal 100 mm diameter or larger is used for vapour transfer, an emergency shutoff valve shall be installed in the piping of the transfer system within 3.1 m from the nearest end of the hose or arm;
(ii) Where the flow is away from the hose, a check valve shall be permitted to be used as the shutoff valve;
(iii) Where either a liquid or vapour line has two or more legs, an emergency shutoff valve shall be installed either in each leg or in the feed line before the legs;
- (f) The operating instructions for dispenser shall be posted near or on the dispenser; and

- (g) Operating instructions identifying the location and operation of emergency controls shall be posted conspicuously in the facility area.
- (2) Vehicle Fuelling Connector:
 - (a) A fuelling connector and mating vehicle receptacle as per ISO 12617 or equivalent shall be used for reliable, safe, and secure transfer of LNG or gas vapour to or from the vehicle, with minimal leakage; and
 - (b) The fuelling connector either shall be equipped with an interlock device that prevents release while the line is open or have self-closing ends that automatically close upon disconnection.
- (3) Installation of Emergency Shutdown Equipment (ESD):
 - (a) An ESD shall be provided with a shutoff valve for stopping liquid supply and shutting down of the transfer equipment;
 - (b) ESD actuator, distinctly marked for easy recognition with a permanently affixed legible sign shall be provided near to the dispenser, LNG unloading facilities and sales or control room;
 - (c) Instrumentation for LNG fueling facilities shall be designed so that, in the event of a power or instrumentation failure, the system goes into a fail-safe condition until the operators either reactivate or shut down the system;
 - (d) All ESDs shall be manually reset; and

15.0 Operation and Maintenance

- (1) Each LNG or LCNG installation or dispensing station shall provide for written operating, maintenance and training procedures. Such procedures shall be drawn based on experience, knowledge of similar facilities;
- (2) Each LNG or LCNG installation / dispensing station shall meet the following requirements, namely: -
 - (a) Have written procedures covering operation, maintenance and training;
 - (b) Keep up-to-date drawings of plant equipment;
 - (c) Have written emergency plan as part of the operations manual;
 - (d) Shall be in liaison with local authorities like Police, Fire Department, Health Authorities and keep them informed about emergency plans and their role in emergency situations; and
 - (e) Have documents wherein safety related malfunctions are identified and analyzed for the purpose of determining their causes and preventing the possibility of reoccurrence.
- (3) Operating Procedures Manual: Every LNG or LCNG installation or dispensing station

shall have a written manual of emergency procedures that shall include a type of emergencies that are anticipated and shall include the following procedures, namely: -

- (a) Start up and shut down procedure including initial startup of the LNG or LCNG facility;
- (b) Purging and inerting components;
- (c) Cooling down components;
- (d) Identify the possibility of abnormal conditions;
- (e) Safety precautions requirement to be taken while repairs or maintenance in the installation is being carried out;
- (f) Procedures for responding to controllable emergencies including notifying personnel and use of equipment's i.e. appropriate to handling of emergency;
- (g) Procedure for recognizing an uncontrollable emergency and for taking action to ensure that harm to the personnel in the premises and to the public outside is limited;
- (h) Procedure for immediate notification of the emergency to the local authorities; and
- (i) Procedure for coordinating with local authorities in the preparation of any evacuation plan which may be required to protect the public in the event of emergency;

(4) Maintenance: -

- (a) Every installation shall have a written procedure based on experience and knowledge of similar facilities and conditions under which the installation shall be maintained;
- (b) The procedure shall incorporate the need to carry out periodic inspection, tests on every equipment and system in service to verify that the equipment is maintained in accordance with the equipment manufacturer's recommendations; and
- (c) The written manual shall set out inspection and maintenance programme for each component forming part of the installation. In addition to fixing a schedule for inspection and tests, the procedure to be followed during repairs so as to ensure safety of persons and property shall also be laid down.

16.0 Road Transportation

1. Design - General Requirements:

The safety relief valves provided on the inner vessel of the LNG transport tank shall be sized to meet most stringent condition of simultaneous occurrence of loss of vacuum and external fire. The combined capacity of the safety valves shall be sufficient to limit the pressure in the vessel to the test pressure, in the following manner. namely: -

- (i) The transport vessel shall be designed and constructed as per the ASME Section VIII Div- I Boiler and pressure vessel code, EN13530 or equivalent code and also to meet the requirements of ISO 20421. The design temperature of the vessel, piping and valves shall be such that it is suitable for requirement sustaining cold shock caused by a loading of liquid Nitrogen into the vessel during its testing and commissioning;
- (ii) Each vessel shall have adequate insulation that will prevent the vessel pressure from exciting the relief valve set pressure within the specified holding time when the vessel is loaded with LNG at the design condition of –
 - a) Specified temperature and pressure of the LNG; and
 - b) Ambient temperature
- (iii) The outer vessel or jacket of the cryogenic vessel for transportation of LNG shall be made of no other material other than steel.; and
- (iv) No Aluminum valve or fitting external to the wetted outer vessel shall be installed on LNG transportation vessels. Each transportation vessel shall consist of a suitably supported welded inner vessel enclosed within an outer shell with vacuum insulation between the two.

2. Structural Integrity:

- (i) The design and construction of each vessel used for transportation of LNG shall be in accordance with ASME Section VIII Div. 1 of ASME Boiler and pressure vessel Code, EN13530 or equivalent code. The vessel design shall include calculation of stress due to design pressure, the weight of lading, the weight of structure supported by the vessel wall, and the effect of the temperature gradients resulting from lading and ambient temperature extremes;
- (ii) In order to account for stresses due to impact in an accident, the design calculation of the vessel shell and heads shall include the load resulting from the design pressure in combination with the dynamic pressure resulting from a longitudinal deceleration of 2g. For this loading condition, the stress value used shall not exceed 75% of the yield strength of the material of construction;
- (iii) The fittings and accessories mounted on the vessel shall be protected in such a way that damage caused by overturning can not impair operational integrity. This protection may take the form of cylindrical profile of the vessel, of strengthening rings, protective canopies or transverse or longitudinal members so shaped that effective protection is given; and
- (iv) The welding of the appurtenances to the vessel wall shall be made of attachment of the mounting pad so that there will be no adverse effect upon the loading retention integrity of the vessel.

3. Pressure Relief Devices, Piping, Valves and Fittings:

- (i) Hoses shall be approved for the service and shall be designed for a bursting pressure of at least five times working pressure;

- (ii) If a threaded pipe is used, the pipe and fitting shall be Scheduled 80 or higher rating;
- (iii) Each hose coupling shall be designed for a pressure of at least 120% of the hose design pressure and there shall be no leakage when connected;
- (iv) Piping shall be protected from damage due to thermal expansion and contraction, jarring and vibration. Slip joints shall not be used;
- (v) Each valve shall be suitable for the vessel design pressure at the vessel design service temperature;
- (vi) All fittings shall be rated for the maximum vessel pressure and suitable for the coldest temperature to which they will be subjected in actual service;
- (vii) When a pressure building coil is used on the vessel, the vapor connection to that coil shall be provided with a valve or check valve as close to the vessel shell as practicable to stop flow in case of damage to the coil. The liquid connection to the coil shall also be provided with a valve;
- (viii) Each vessel shall be rated for its holding time as per ISO 21014, the holding time being the time as determined by testing that will elapse from loading until the pressure of the contents, under equilibrium conditions reaches the level of the lowest pressure relief valve setting;
- (ix) Rupture discs shall not be used on the LNG transport vessels; and
- (x) The outer vessel shall be protected by any accidental accumulation of pressure in the annular space by using a relief plate or plug or a rupture disc. The relief device shall function at a pressure of 25 psi or the internal design pressure of the outer tank or the external design pressure of the inner tank, whichever is less.

4. Damage Protection During Transportation

- (i) All valves, fittings, pressure relief devices and other accessories to the vessels, which are not isolated from the vessel by closed intervening shut off valves or check valves shall be installed within the framework of motor vehicle or within a suitable collision resistant guard or housing. Further, appropriate ventilation shall also be provided;
- (ii) Each pressure relief device shall be protected so that in the event of the upset of the vehicle on a hard surface, the device's opening will not be prevented and its discharge will not be restricted;
- (iii) The threaded end connection safety valves are preferred in stainless steel body construction;
- (iv) Each protective device or housing and its attachment to the vehicle structure shall be designed to withstand static loading in any direction that it may be loaded as a result of front, rear, side or sideswipe collision or the overturning of the vehicle; and
- (v) All the valves of tank shall be at rear inside on operation box (cabinet) of suitable

size and shall not project out of tank frame.

5. Rear End Protection:

- (i) Rear end vessel protection devices shall consist of at least one rear bumper designed to protect the transport vessel and piping in the event of a rear end collision;
- (ii) The rear end vessel protection device shall be designed so that it transmits the force of the collision directly to the chassis of the vehicle;
- (iii) The rear end vessel protection device and its attachments to the chassis shall be designed to withstand a load equal to twice the weight of the loaded cargo vessel and attachments, using a safety factor of four based on the tensile strength of the materials used with such load being applied horizontally and parallel to the major axis of the transport vessel; and
- (iv) Every part of the loaded transport vessel and any associated valve, pipe, and enclosure or protected fitting or structure shall be at least 35.5 cm above ground level.

6. Discharge Control Devices:

- (i) Each liquid filling and liquid discharge line shall be provided with a shut off valve located as close to the vessel as practicable. Unless this valve is manually operable at the valve, the line shall also have a manual shut off valve;
- (ii) Each liquid filling and liquid discharge line shall be provided with an on vehicle remotely controlled self-closing shutoff valve;
- (iii) Each control valve shall be of fail-safe design and spring- based;
- (iv) Each remotely controlled shut off valve shall be provided with on vehicle remote means of automatic closure, both mechanical and thermal; and
- (v) One means may be used to close more than one remotely controlled valve. Remote means of automatic closure shall be installed at the ends of the tanker farthest away from the loading or unloading connection area.

7. Shear Section:

Unless the valve is located in a rear cabinet forward of and protected by the bumper, the design and installation of each valve, damage to which could result in loss of liquid or vapor shall incorporate a shear section or breakage groove adjacent to and outboard of the valve. The shear section or breakage groove shall yield or break under strain without damage to the valve that would allow the loss of liquid or vapour.

8. Supports and Anchoring:

In case, the transport tanker vehicle is so designed and constructed that the vessel is not wholly supported by the vehicle frame, the transport vessel shall be supported by external cradles or load rings. The design calculations for the supports and load bearing vessel and the support attachments shall include beam stress, shear stress, torsion stress, bending moment and acceleration stress for the loaded vehicle as a unit, using a safety factor of four based on the tensile strength of the material and static loading that uses the weight of the transport vessel and its attachments when filled to the design weight of the loading. Minimum static loadings shall be maximum of the following individually, namely

- (i) Vertically downward of two (2);
- (ii) Vertically upward of one and half (1.5);
- (iii) Longitudinally of one and half (1.5); and
- (iv) Laterally of one and half (1.5).

9. Gauging Devices:

(i) Liquid level gauging devices:

The vessel shall have one liquid level device that provides a continuous level indication ranging from full to empty and that is maintainable or replaceable without taking the vessel out of service;

(ii) Pressure gauges:

Each vessel shall be equipped with a pressure gauge connected to the vessel at a point above the maximum liquid level that has a permanent mark indicating the maximum allowable working pressure of the tanker. The pressure gauge shall be housed in a canopy of the tanker.

17.0 Competence Assessment and Assurance

1. The objective is to provide good understanding of all the facets of dispensing activities including operations, procedures, maintenance and hazards of LNG or LCNG and the risks associated with handling of the product. Training shall ensure that the jobs are performed in accordance with the laid down procedures and practices.
2. Every entity shall develop, implement, and maintain a written training plan to instruct all LNG or LCNG dispensing station personnel with respect to the following, namely:
 - (i) Carrying out the emergency procedures that relate to their duties at the LNG or LCNG dispensing station as set out in the procedure manual and providing first aid;

(ii) Permanent maintenance, operating, and supervisory personnel with respect to the following, namely:

- (a) The basic operations carried out at the LNG or LCNG installation and dispensing station;
- (b) The characteristics and potential hazards of LNG or LCNG and other hazardous fluids involved in operating and maintaining the LNG or LCNG installation and dispensing station, including the serious danger from frostbite that can result upon contact with LNG;
- (c) The methods of carrying out their duties of maintaining and operating as set out in the manual of operating, maintenance and transfer procedures;
- (d) Fire prevention, including familiarization with the fire control plan of the LNG or LCNG installation or dispensing station; fire fighting; the potential causes of fire or accident in LNG or LCNG installation or dispensing station; the types, sizes, and likely consequences of a fire or accident at a LNG or LCNG installation or dispensing station;
- (e) Recognizing situations when it is necessary for the person to obtain assistance in order to maintain the security of the LNG or LCNG installation or dispensing station; and
- (f) To provide first aid

3. Training shall be imparted to the staff attached with the LNG or LCNG dispensing station at the time of induction, which is to be followed up by periodic refresher courses once every year. The training programme shall inter alia cover following aspects, namely:

- (i) Hazardous characteristics of LNG or LCNG;
- (ii) Familiarisation with operational procedures and practices;
- (iii) Commissioning of new facilities and equipment;
- (iv) Hands on experience on operation of equipment;
- (v) Routine maintenance activities of the facilities;
- (vi) Knowledge of emergency and manual shut down systems;
- (vii) Immediate and effective isolation of any LNG or LCNG leak;
- (viii) Accounting of product;
- (ix) Safety regulations and accident prevention;
- (x) Fire fighting facilities, methods of firefighting and its upkeep;
- (xi) Evacuation and safe egress of the vehicles;
- (xii) Housekeeping;
- (xiii) Safety in transportation of LNG or LCNG;
- (xiv) First aid;
- (xv) Emergency plan or drills;

- (xvi) Natural gas leakage possibility and its containment;
- (xvii) Filling nozzles, types of gasket or seal and like others of the same kind; and
- (xviii) Access control of vehicles so as to allow the vehicle with tested cylinders to be filled with CNG.

4. Appropriate training techniques shall be adopted which will include, the following, namely:

- (i) Classroom training;
- (ii) Hands on/ practical training;
- (iii) Demonstration;
- (iv) Case studies; and
- (v) Training aids.

5. Each entity shall ensure that all personnel receive applicable training and have experience related to their assigned duties. Any person who has not completed the training or received experience shall be under the control of trained personnel.

6. Proper records for the training and refresher courses shall be maintained at the installation.

18.0 Emergency Plan and Procedure

1. A comprehensive Emergency Response and Disaster Management Plan (ERDMP) shall be developed in accordance to the Petroleum and Natural Gas Regulatory Board (Codes of Practices for Emergency Response and Disaster Management Plan (ERDMP)) Regulations, 2010. The copies of the ERDMP shall be available to all personnel at the CNG dispensing station.
2. Provision of minimum 2 points for emergency shutdown shall be maintained:

The entity having control over the dispensing station shall draw an operational emergency plan in consultation with adjoining establishments and local authorities such as fire brigade, police, and other District Emergency Authorities and like other authorities for the following circumstances, namely:

- (i) Loss of or interruption to the gas supplies due to leaks or failure of pipeline;
- (ii) Over-odorisation of the gas;
- (iii) Major failure of LCNG or LNG fittings;
- (iv) Accidents or other emergencies, which can affect the L-CNG or LNG dispensing station;
- (v) Civil emergencies;
- (vi) Emergency situations during transportation of LNG through Tanker and LCNG through mobile cascade vehicles; and

- (vii) Any other risk arising from the existence or use of the LCNG or LNG dispensing station.
- 3. The emergency plan specified in sub-para 18(2) shall be disseminated amongst all personnel involved and ensured that they understand their roles and responsibilities in the event of an emergency.
- 4. The operator of the dispensing station should have close liaison with Fire Service, the Police, the Municipal Authorities and the person supplying gas to CNG facility.
- 5. Important telephone numbers for emergency use shall be displayed prominently.
- 6. Means of communication shall be always at the disposal of the in charge of the installation on 24 hours basis.
- 7. First aid kit shall contain items to handle possible emergencies as per rules applicable to factories in the concerned State for such purpose;
- 8. Electrical shock treatment chart written in bilingual (English and local languages) and RO attendants shall be given training on how to treat an electrocuted person before help from a doctor is available, and
- 9. Approved Security Procedures duly documented shall be maintained at LNG or LCNG installation.

19.0 Automation:

The automation (Forecourt Control) where provided, shall comply with the provisions as specified clause 5.0 of Schedule – 1.

20.0 Safety Inspections or Audit

The safety inspections or audit of CNG dispensing station shall be carried out as given below, namely:

TYPE	FREQUEMCY	AGENCY
General Inspection	Daily	Operating personnel
	Twice in a quarter	Authorised personnel of marketing company
Safety Audit	Once in a year	Authorised Person
Electrical Audit	Once in three years	Licensed Electrical agency

Note: The comprehensive checklist shall be developed in line with the similar checklists provided in Schedule – 1.]

Layout – I. Typical layout of Auto LNG/ LCNG station with provision of mobile cascade filling and PNG

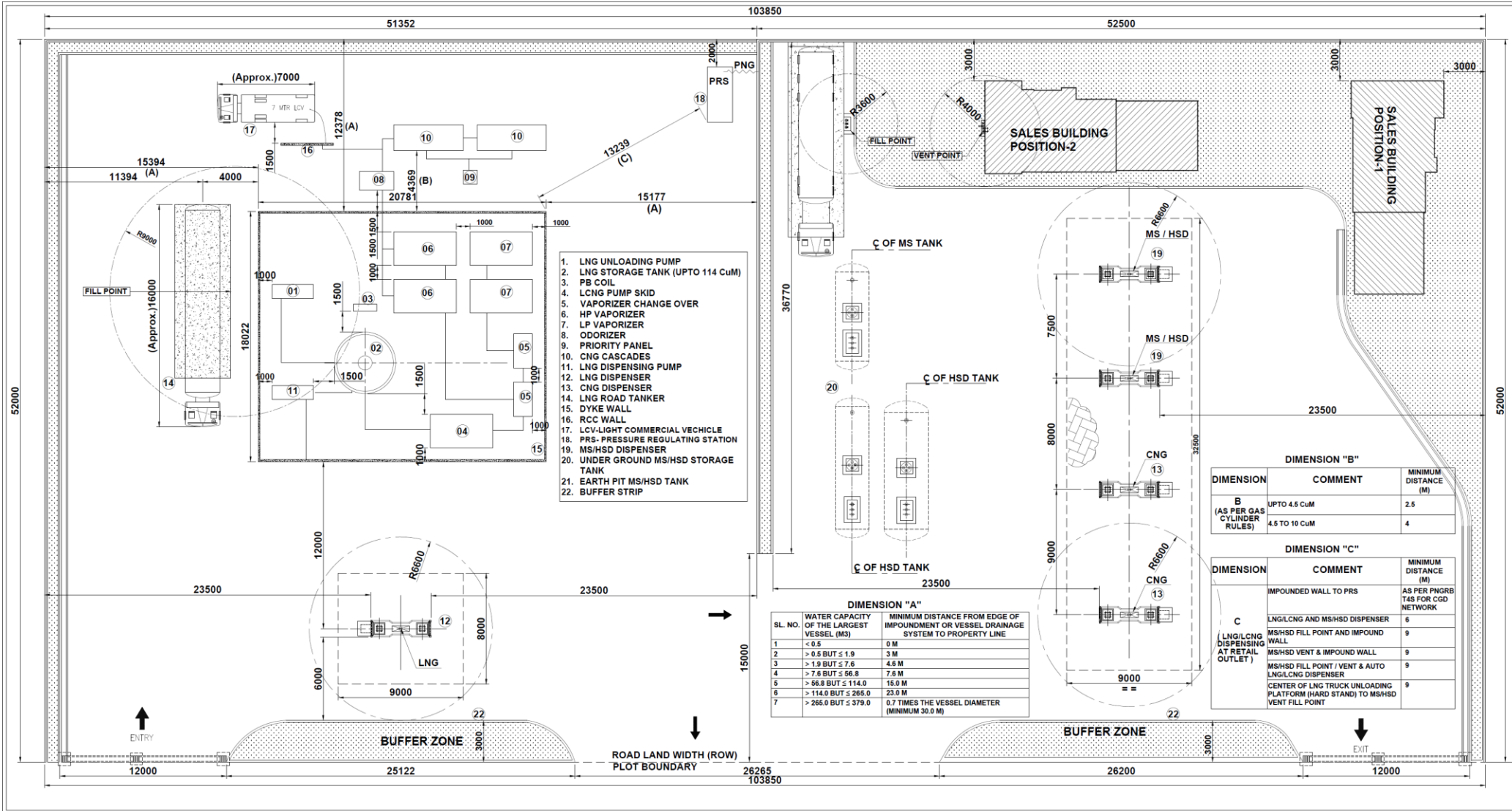

Footnote: The Principal regulations were notified in the official gazette *vide* F. No. INFRA/T4S/SC-6/4/2018, dated 6th November, 2018 and amended *vide* F. No. PNGRB/Tech/5-T4SRO/(2)/2020 dated 15th September, 2020.